

STA801M 2-Output Separate Excitation Switching Mode Regulator ICs

Features

- 2 regulators combined in 1 package
- Compact inline package
- Output current (0.5A × 2 outputs)
- Output voltage of Ch2 selectable from 4 levels
- Built-in flywheel diode (Schottky barrier diode)
- Requires only 7 discrete components (2 outputs)
- Internally-adjusted phase corrections and output voltages
- Built-in reference oscillator (125kHz) - Enables to downsize a choke-coil due to IC's high oscillating frequency. (Compared with conventional Sanken devices)
- Built-in overcurrent and thermal protection circuits
- Built-in soft start circuits (Output ON/OFF available)

Lineup

Part Number	Output Voltage (V)	
	Ch1	Ch2(Select one output)
STA801M	5	9.0 / 11.5 / 12.1 / 15.5

Absolute Maximum Ratings

Parameter	Symbol	Ratings	Unit
DC Input Voltage	V _{IN}	43	V
Power Dissipation	P _{D1}	6.7(With infinite heatsink)	W
	P _{D2}	1.6(Without heatsink, stand-alone operation)	W
Junction Temperature	T _j	+125	°C
Storage Temperature	T _{stg}	-40 to +125	°C

Applications

- For BS and CS antenna power supplies
- For stabilization of the secondary stage of switching power supplies
- Electronic equipment

Recommended Operating Conditions

Parameter	Symbol	Ratings		Unit
		min.	max.	
DC Input Voltage Range	V _{IN}	Ch2 V _{Omax} +2	40	V
Output Current Range per Channel	I _o	0	0.5	A
Operating Temperature Range	T _{top}	-20	+125	°C

Electrical Characteristics

(T_a=25°C)

	Parameter	Symbol	Ratings			Unit	
			STA801M				
			min.	typ.	max.		
Ch1	Output voltage 1	V _{O1}	4.80	5.00	5.20	V	
	Conditions		V _{IN} =20V, I _o =0.3A				
	Efficiency *	η ₁		80		%	
	Conditions		V _{IN} =20V, I _o =0.3A				
	Temperature Coefficient of Output Voltage	ΔV _O /ΔT _{a1}		±0.5		mV/°C	
	Line Regulation	ΔV _{OLINE1}		30	90	mV	
Conditions		V _{IN} =10 to 30V, I _o =0.3A					
Load Regulation	ΔV _{OLOAD1}		10	40	mV		
	Conditions		V _{IN} =20V, I _o =0.1 to 0.4A				
Ch2 (Select one output)	Output voltage 2-1	V _{O2-1}	8.64	9.00	9.36	V	
	Conditions		V _{IN} =20V, I _o =0.3A				
	Output voltage 2-2	V _{O2-2}	11.04	11.50	11.96	V	
	Conditions		V _{IN} =20V, I _o =0.3A				
	Output voltage 2-3	V _{O2-3}	11.62	12.10	12.58	V	
	Conditions		V _{IN} =20V, I _o =0.3A				
	Output voltage 2-4	V _{O2-4}	14.88	15.50	16.12	V	
	Conditions		V _{IN} =20V, I _o =0.3A				
	Vo2-4	Efficiency*	η		89		%
		Conditions		V _{IN} =20V, I _o =0.3A			
Temperature Coefficient of Output Voltage		ΔV _O /ΔT _a		±2.0		mV/°C	
Line Regulation		ΔV _{OLINE}		40	130	mV	
Conditions		V _{IN} =20 to 30V, I _o =0.3A					
Load Regulation	ΔV _{OLOAD}		30	120	mV		
	Conditions		V _{IN} =20V, I _o =0.1 to 0.4A				
Common	No-load Circuit Current	I _{cc}		15		mA	
	Oscillation Frequency	f		125		kHz	
	Overcurrent Protection Starting Current	I _{s1}	0.51	0.7		A	

* Efficiency indicates the value when only one channel is active. The value can be calculated as shown below. 7.5mA is deducted for the no-load circuit current of $\frac{I_{cc}}{2}$ at unused output.

$$\eta = \frac{V_O \cdot I_o}{V_{IN} \cdot (I_{IN} - 0.0075)} \times 100(\%)$$

External Dimensions (SIP10 [STA 10Pin])

(Unit : mm)

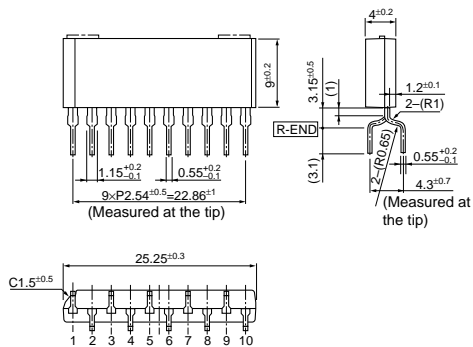

Pin Assignment

- | | |
|------------|----------------------------|
| ① Vo2 Cont | ⑧ SS2 |
| ② Vos1 | ⑨ Vos2-2 |
| ③ SS1 | ⑩ Vos2-1 |
| ④ SWOUT1 | |
| ⑤ GND | Plastic Mold Package Type |
| ⑥ VIN | Flammability: UL94V-0 |
| ⑦ SWOUT2 | Product Mass: Approx. 2.5g |

Block Diagram

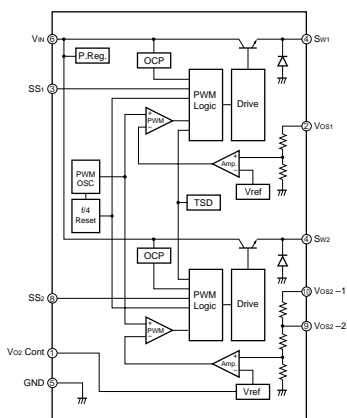

Typical Connection Diagram

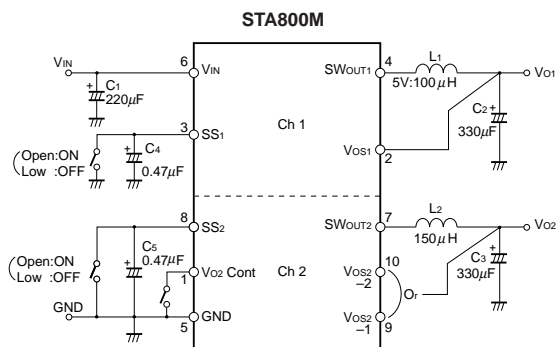

For how to connect VOS2-1 and VOS2-2 of Channel 2, refer to the output selection method on the Sanken web site.

Ta-Pd Characteristics

