

SPI-8001TW/SPI-8002TW/SPI-8003TW 2-Output, Step-down Switching Mode

■ Features

- 2 regulators combined in one package
- Output current: 1.5A × 2 (HSOP 16 Pin Surface mount package)
- High efficiency: TYP80% (SPI-8001TW), TYP78% (SPI-8002TW)
- Variable output voltage: 1.0 to 16V (SPI-8001TW), 1.0 to 24V (SPI-8002TW)
- Built-in reference oscillator (250kHz): Enables to downsize a choke-coil
- Low circuit current consumption: $\leq 1\mu\text{A}$ (at output OFF)
- High accuracy reference voltage: $\pm 1\%$
- Built-in foldback-overcurrent and thermal protection circuits
- Built-in ON/OFF circuit (soft start available) – per output

■ Applications

- Onboard local power supplies
- OA equipment
- For stabilization of the secondary-side output voltage of switching power supplies

■ Absolute Maximum Ratings*1

Parameter	Symbol	Ratings			Unit
		SPI-8001TW	SPI-8002TW	SPI-8003TW	
Input Voltage	V_{IN}	21	40	40	V
	V_{CC}	21	40	40	V
	$V_{C/E}$	21	40	40	V
Power Dissipation*2, *3	P_D	3.0			W
Junction Temperature	T_J	+135		+150	°C
Storage Temperature	T_{stg}	-40 to +135		-40 to +150	°C
Thermal Resistance (junction to case)*2	θ_{j-c}	9.0			°C/W
Thermal Resistance (junction to ambient air)*2	θ_{j-a}	35.8			°C/W

*1: Absolute maximum ratings show the destructive limit. No parameter should exceed the ratings in transient or normal operations.

*2: When mounted on glass-epoxy board 70cm² (copper laminate area 30.8cm²).

*3: Limited by thermal protection.

■ Recommended Operating Conditions*1

Parameter	Symbol	Ratings						Unit
		SPI-8001TW		SPI-8002TW		SPI-8003TW		
		min.	max.	min.	max.	min.	max.	
Input Voltage Range	V_{IN}	V_{O+3}	20	V_{O+3}	38	V_{O+3}	38	V
	V_{CC}	4.5	20	4.5	38	4.5	38	V
	$V_{C/E}$		20		38		38	V
Output Voltage Range	V_O	1	16	1	24	1	24	V
Output Current Range	I_O		1.5		1.5		1.5	A
Operating Junction Temperature Range	T_{jop}	-30	+135	-30	+135	-30	+125	°C
Operating Temperature Range	T_{op}	-30	+135	-30	+135	-30	+85	°C

*1: Recommended operating conditions show the operating conditions required for the normal circuit function described in the electrical characteristics. These conditions must be followed in actual use.

■Electrical Characteristics*1

(Ta=25°C)

Parameter	Symbol	Ratings									Unit	
		SPI-8001TW			SPI-8002TW			SPI-8003TW				
		min.	typ.	max.	min.	typ.	max.	min.	typ.	max.		
Reference Voltage	VREF	0.996	1.006	1.016	0.996	1.006	1.016	0.966	1.006	1.016	V	
	Conditions	VIN=10V, VO=1V, IO=0.1A						VIN=14V, IO=0.1A				
Temperature Coefficient of Reference Voltage	ΔVREF/ΔT		±0.1			±0.1			±0.1		mV/°C	
	Conditions	VIN=10V, VO=1V, IO=0.1A, Ta=-30 to +135°C						VIN=14V, IO=0.1A, Ta=-30 to +125°C				
Efficiency 1 ²	Eff1		80			78			78		%	
	Conditions	VIN=VCC=15V, VO=5V, IO=0.5A, IIN: including Icc						VIN=VCC=14V, VO=5V, IO=0.5A, IIN: including Icc				
Efficiency 2 ²	Eff2		83			81			81		%	
	Conditions	VIN=15V, VO=5V, IO=0.5A, VCC=5V, IIN: excluding Icc						VIN=14V, VCC=5V, VO=5V, IO=0.5A, IIN: excluding Icc				
Oscillation Frequency	fosc		250		215	250	285	200		400	kHz	
	Conditions	VIN=VCC=15V, VO=5V, IO=0.5A						VIN=14V, IO=0.1A, COsc=100pF				
Line Regulation	VLINE		30	60		30	60		30	60	mV	
	Conditions	VIN=VCC=10 to 20V, VO=5V, IO=1A						VIN=VCC=9 to 18V, VO=5V, IO=1A				
Load Regulation	VLOAD		10	40		10	40		10	40	mV	
	Conditions	VIN=VCC=15V, VO=5V, IO=0.2 to 1.5A						VIN=VCC=14V, VO=5V, IO=0.2 to 1.5A				
Overcurrent Protection Starting Current	IS	1.6			1.6			1.6			A	
	Conditions	VIN=VCC=15V						VIN=VCC=14V				
Quiescent Circuit Current 1	IIN		4			4			4		mA	
	Conditions	VIN=15V, VCC=5V, IO=0V, VO≤12V						VIN=14V, VCC=5V, IO=0A, VO≤12V				
Quiescent Circuit Current 2	Icc		8.5			8.5			8.5		mA	
	Conditions	VCC=15V, IO=0A						VCC=14V, IO=0A				
Quiescent Circuit Current 3	IIN (off)			1			1			1	μA	
	Conditions	VIN=15V, VC/E=0V or Open						VIN=14V, VC/E=0V or Open				
Quiescent Circuit Current 4	Icc (off)			1			1			1	μA	
	Conditions	VCC=15V, VC/E=0V or Open						VIN=14V, VC/E=0V or Open				
Quiescent Circuit Current 5	IIN (ssov)								4		mA	
	Conditions	—						VIN=14V, VCC=5V, IO=0A, SS1=SS2=0V				
Quiescent Circuit Current 6	Icc (ssov)								8.5		mA	
	Conditions	—						VCC=14V, IO=0V, SS1=SS2=0V				
C/E Pin	High Level Voltage	VC/EH	2			2			2		V	
		Conditions	VIN=VCC=15V						VIN=VCC=14V			
	Low Level Voltage	VC/EL			0.8			0.8			0.8	V
		Conditions	VIN=VCC=15V						VIN=VCC=14V			
Inflow Current at High	IC/EH		95			95			95		μA	
	Conditions	VC/E=20V						VC/E=20V				
SS Pin ³	Low Level Voltage	VSSL			0.5		0.5			0.5	V	
		Conditions	VIN=VCC=15V						VIN=VCC=14V			
	Inflow Current at Low	ISSL		60	80		60	80		60	80	μA
		Conditions	VSSL=0V, VIN=VCC=15V						VSSL=0V, VIN=VCC=14V			

*1: Electrical characteristics show the characteristic ratings guaranteed when operating the ICs under the measurement conditions described in the above table.

*2: Efficiency is calculated from the following formula.

$$\eta (\%) = \frac{V_O \cdot I_O}{V_{IN} \cdot I_{IN}} \times 100$$

*3: Pin 6 and pin 11 are the SS pins. Soft start at power on can be performed with capacitors connected to these pins. The outputs can also be turned ON/OFF with these pins. The outputs are stopped by setting the voltages of these pins to VSSL or lower. SS-pin voltages can be changed with open-collector drive circuits of transistors.

When using both the soft-start and ON/OFF functions together, the discharge currents from C4 and C5 flow into the ON/OFF control transistors respectively. Therefore, limit the currents securely to protect the transistors if C4 and C5 capacitances are large. The SS pins are pulled up to the power supply in the ICs, so applying the external voltages are prohibited.

Typical Connection Diagram

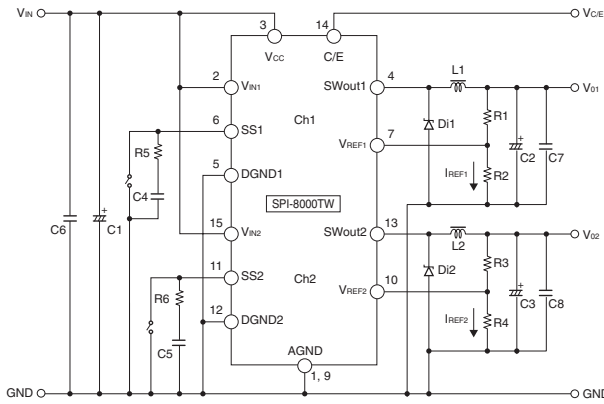

- C1 : 220 μF/50V
- C2, C3 : 470 μF/25V
- C4, C5 : 1 μF
- C6, C7, C8 : 0.1 μF
- R5, R6 : 1kΩ
- L1, L2 : 47 μH
- Di1, Di2 : SJPB-H6 (Sanken)

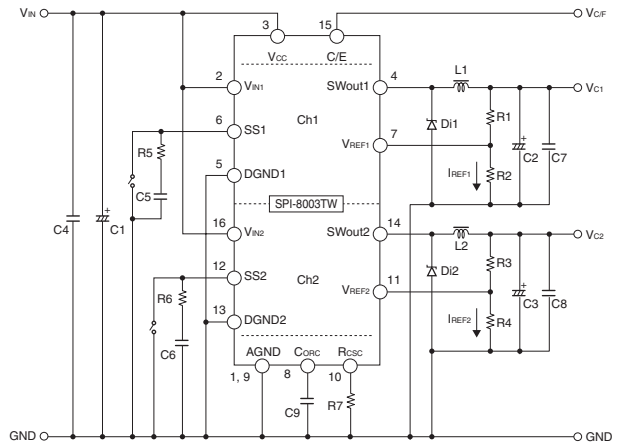

- C1 : 220 μF/50V
- C2, C3 : 470 μF/25V
- C4 : 1 μF/50V
- C5, C6 : 1 μF/10V
- C7, C8 : 0.1 μF/50V
- C9 : 100pF/10V
- L1, L2 : 47 μH
- R2, R4 : 1kΩ
- R5, R6 : 1kΩ
- Di1, Di2 : SJPB-H6 (Sanken)

Diodes Di1, Di2

- Be sure to use Schottky-barrier diodes for Di1 and Di2.
- If other diodes like fast recovery diodes are used, IC may be destroyed because of the reverse voltage generated by the recovery voltage or ON voltage.

Choke coils L1, L2

- If the winding resistance of the choke coil is too high, the efficiency may drop below the rated value.
- As the overcurrent protection starting current is about 2.0A, take care concerning heat radiation from the choke coil caused by magnetic saturation due to overload or short-circuited load.
- Use a closed-magnetic-path coil to prevent interference between the channels SWout1 and SWout2.

Capacitors C1, C2, C3

- As large ripple currents flow through C1, C2 and C3, use high-frequency and low-impedance capacitors suitable for switching mode power supplies. Especially when the impedance of C2 and C3 are high, the switching waveforms may become abnormal at low temperatures. For C2 and C3, do not use capacitors with extremely low equivalent series resistance (ESR) such as OS capacitors or tantalum capacitors, which may cause abnormal oscillation.

Resistors R1, R2, R3, R4

- R1, R2, R3 and R4 are resistors for setting output voltages. Set the resistors so that IREF is approx. 1 mA. For example, R1 and R2 can be calculated as shown below.

$$R1 = \frac{(V_{O1} - V_{REF1})}{I_{REF1}} = \frac{(V_{O1} - V)}{1 \times 10^{-3}} (\Omega), R2 = \frac{V_{REF1}}{I_{REF1}} = \frac{1}{1 \times 10^{-3}} \approx 1(K\Omega)$$

© To create the optimum operating conditions, place the components as close as possible to each other.

Ta-Pd Characteristics

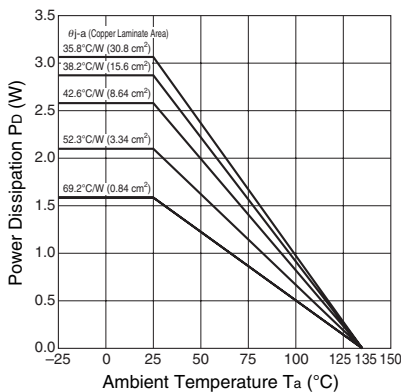

$$P_D = V_O \cdot I_O \left(\frac{100}{\eta\%} - 1 \right) - V_F \cdot I_O \left(1 - \frac{V_O}{V_{IN}} \right)$$

- VO : Output Voltage
- VIN : Input Voltage
- IO : Output Current
- η% : Efficiency (%)
- VF : D1 Forward Voltage
SJPB-H6...0.45V (IO=1A)

Note 1: The efficiency depends on the input voltage and the output current. Therefore, obtain the value from the efficiency graph and substitute the percentage in the formula above.

Note 2: Thermal design for D1 must be considered separately.