

**SLA7022MU/SLA7029M/SMA7022MU/SMA7029M 2-Phase Excitation**

**Absolute Maximum Ratings**

(T<sub>a</sub>=25°C)

Parameter	Symbol	Ratings				Unit
		SLA7022MU	SLA7029M	SMA7022MU	SMA7029M	
Motor Supply Voltage	V <sub>CC</sub>	46				V
FET Drain-Source Voltage	V <sub>DSS</sub>	100				V
Control Supply Voltage	V <sub>S</sub>	46				V
TTL Input Voltage	V <sub>IN</sub>	7				V
Reference Voltage	V <sub>REF</sub>	2				V
Output Current	I <sub>O</sub>	1	1.5	1	1.5	A
Power Dissipation	P <sub>D1</sub>	4.5 (Without Heatsink)		4.0 (Without Heatsink)		W
	P <sub>D2</sub>	35 (T <sub>c</sub> =25°C)				28 (T <sub>c</sub> =25°C)
Channel Temperature	T <sub>Ch</sub>	+150				°C
Storage Temperature	T <sub>Stg</sub>	-40 to +150				°C

**Electrical Characteristics**

(T<sub>a</sub>=25°C)

Parameter	Symbol	Ratings												Unit	
		SLA7022MU			SLA7029M			SMA7022MU			SMA7029M				
		min.	typ.	max.	min.	typ.	max.	min.	typ.	max.	min.	typ.	max.		
Control Supply Current	I <sub>S</sub>	10			15			10			15			mA	
	Condition	V <sub>S</sub> =44V			V <sub>S</sub> =44V			V <sub>S</sub> =44V			V <sub>S</sub> =44V				
Control Supply Voltage	V <sub>S</sub>	10	24	44	10	24	44	10	24	44	10	24	44	V	
FET Drain-Source Voltage	V <sub>DSS</sub>	100			100			100			100			V	
	Condition	V <sub>S</sub> =44V, I <sub>DSS</sub> =250μA			V <sub>S</sub> =44V, I <sub>DSS</sub> =250μA			V <sub>S</sub> =44V, I <sub>DSS</sub> =250μA			V <sub>S</sub> =44V, I <sub>DSS</sub> =250μA				
FET ON Voltage	V <sub>DS</sub>	0.85			0.6			0.85			0.6			V	
	Condition	I <sub>D</sub> =1A, V <sub>S</sub> =14V			I <sub>D</sub> =1A, V <sub>S</sub> =14V			I <sub>D</sub> =1A, V <sub>S</sub> =14V			I <sub>D</sub> =1A, V <sub>S</sub> =14V				
FET Drain Leakage Current	I <sub>DSS</sub>	4			4			4			4			mA	
	Condition	V <sub>DSS</sub> =100V, V <sub>S</sub> =44V			V <sub>DSS</sub> =100V, V <sub>S</sub> =44V			V <sub>DSS</sub> =100V, V <sub>S</sub> =44V			V <sub>DSS</sub> =100V, V <sub>S</sub> =44V				
FET Diode Forward Voltage	V <sub>SD</sub>	1.2			1.1			1.2			1.1			V	
	Condition	I <sub>D</sub> =1A			I <sub>D</sub> =1A			I <sub>D</sub> =1A			I <sub>D</sub> =1A				
TTL Input Current	I <sub>IH</sub>	40			40			40			40			μA	
	Condition	V <sub>IH</sub> =2.4V, V <sub>S</sub> =44V			V <sub>IH</sub> =2.4V, V <sub>S</sub> =44V			V <sub>IH</sub> =2.4V, V <sub>S</sub> =44V			V <sub>IH</sub> =2.4V, V <sub>S</sub> =44V				
	I <sub>IL</sub>	-0.8			-0.8			-0.8			-0.8				
TTL Input Voltage (Active High)	Condition	V <sub>IL</sub> =0.4V, V <sub>S</sub> =44V			V <sub>IL</sub> =0.4V, V <sub>S</sub> =44V			V <sub>IL</sub> =0.4V, V <sub>S</sub> =44V			V <sub>IL</sub> =0.4V, V <sub>S</sub> =44V			mA	
	V <sub>IH</sub>	2			2			2			2				
	Condition	I <sub>D</sub> =1A			I <sub>D</sub> =1A			I <sub>D</sub> =1A			I <sub>D</sub> =1A				
TTL Input Voltage (Active Low)	V <sub>IL</sub>		0.8			0.8			0.8			0.8		V	
	Condition	V <sub>DSS</sub> =100V			V <sub>DSS</sub> =100V			V <sub>DSS</sub> =100V			V <sub>DSS</sub> =100V				
	V <sub>IH</sub>	2			2			2			2				
Switching Time	Condition	V <sub>DSS</sub> =100V			V <sub>DSS</sub> =100V			V <sub>DSS</sub> =100V			V <sub>DSS</sub> =100V			μs	
	V <sub>IL</sub>		0.8			0.8			0.8			0.8			
	Condition	I <sub>D</sub> =1A			I <sub>D</sub> =1A			I <sub>D</sub> =1A			I <sub>D</sub> =1A				
AC Characteristics	Switching Time	T <sub>r</sub>	0.5			0.5			0.5			0.5			μs
		Condition	V <sub>S</sub> =24V, I <sub>D</sub> =0.8A			V <sub>S</sub> =24V, I <sub>D</sub> =1A			V <sub>S</sub> =24V, I <sub>D</sub> =0.8A			V <sub>S</sub> =24V, I <sub>D</sub> =1A			
		T <sub>sig</sub>	0.7			0.7			0.7			0.7			
		Condition	V <sub>S</sub> =24V, I <sub>D</sub> =0.8A			V <sub>S</sub> =24V, I <sub>D</sub> =1A			V <sub>S</sub> =24V, I <sub>D</sub> =0.8A			V <sub>S</sub> =24V, I <sub>D</sub> =1A			
		T <sub>f</sub>	0.1			0.1			0.1			0.1			
Condition	V <sub>S</sub> =24V, I <sub>D</sub> =0.8A			V <sub>S</sub> =24V, I <sub>D</sub> =1A			V <sub>S</sub> =24V, I <sub>D</sub> =0.8A			V <sub>S</sub> =24V, I <sub>D</sub> =1A					

Internal Block Diagram

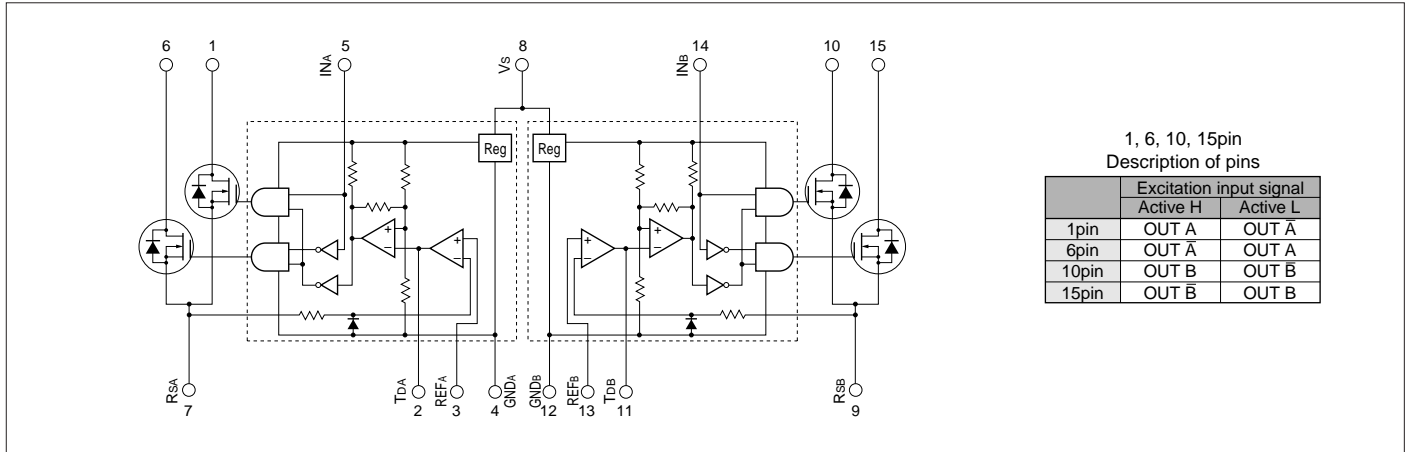

Typical Connection Diagram (Recommended component values)

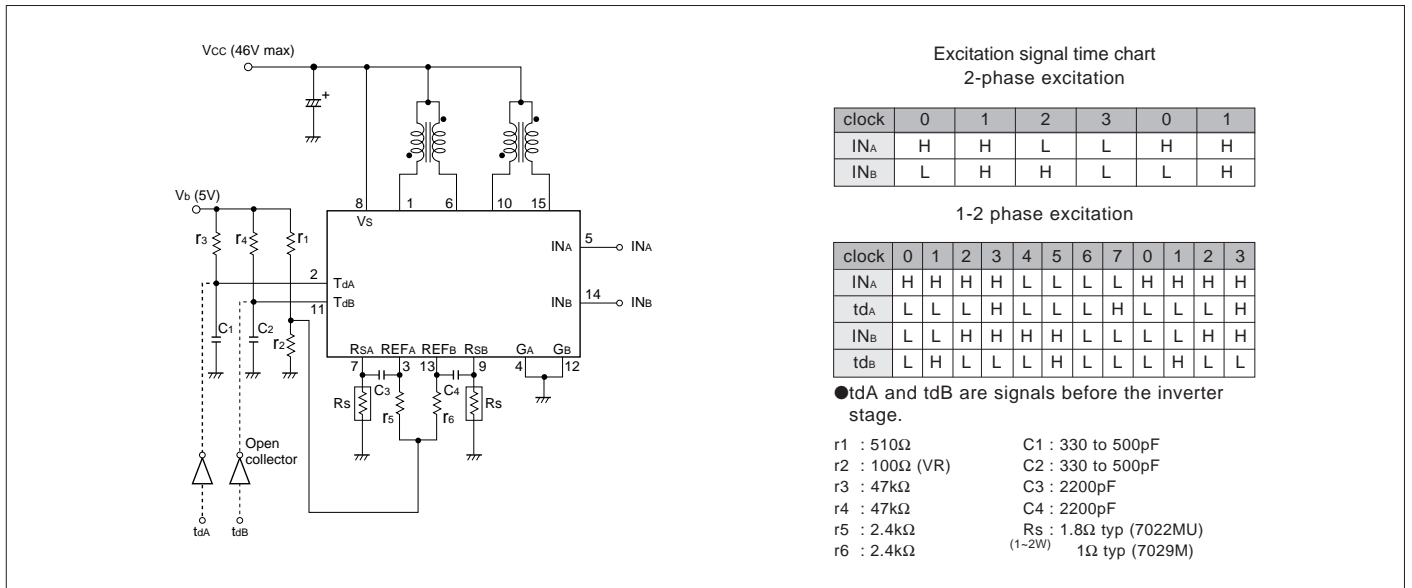

External Dimensions (ZIP15 with Fin [SLA15Pin] /ZIP15[SMA15Pin])

(Unit:mm)

