

## Specifications List by Application Sink Driver Arrays

### ● Built-in Avalanche Diodes, between Collector and Base

Part Number	Circuit Count	V <sub>CE0</sub> (V)/ V <sub>DSS</sub> (V)	I <sub>c</sub> (A)/ I <sub>D</sub> (A)	h <sub>FE</sub> (min)	R <sub>Ds(ON)</sub> max (Ω)	Equivalent Circuit	Package
STA460C	2	60±10	6	700		1	SIP10 (STA10Pin)
STA301A	3	60±10	4	1000		2	SIP8 (STA8Pin)
SDC06	4	30 to 45	2	400		3	PS16 (Surface-Mount)
STA413A	4	35±5	3	500		4	SIP10 (STA10Pin)
STA481A	4	60±10	1	2000		5	SIP10 (STA10Pin)
SDC03	4	60±10	1.5	2000		6	PS16 (Surface-Mount)
STA471A	4	60±10	2	2000		5	SIP10 (STA10Pin)
STA401A	4	60±10	4	1000		5	SIP10 (STA10Pin)
STA406A	4	60±10	6	2000		5	SIP10 (STA10Pin)
STA485A	4	100±15	1	2000		5	SIP10 (STA10Pin)
SDC04	4	100±15	1.5	2000		6	PS16 (Surface-Mount)
STA475A	4	100±15	2	2000		5	SIP10 (STA10Pin)

### ● Built-in Flywheel Diodes

Part Number	Circuit Count	V <sub>CE0</sub> (V)/ V <sub>DSS</sub> (V)	I <sub>c</sub> (A)/ I <sub>D</sub> (A)	h <sub>FE</sub> (min)	R <sub>Ds(ON)</sub> max (Ω)	Equivalent Circuit	Package
SDH02	4	100	1.5	2000		8	PS16 (Surface-Mount)
SMA4033	4	100	2	2000		9	SIP12 (SMA12Pin)
SMA4032	4	100	3	2000		9	SIP12 (SMA12Pin)
SMA5106	4	100	4		0.55	7	SIP12 (SMA12Pin)
SLA4031	4	120	4	2000		9	SIP12 with Fin (SLA12Pin)
SLA4061	4	120	5	2000		9	SIP12 with Fin (SLA12Pin)
SLA4041	4	200	3	1000		9	SIP12 with Fin (SLA12Pin)
SMA4036	6	120	2	2000		10	SIP15 (SMA15Pin)
SLA4051	9	120	2	2000		11	SIP12 with Fin (SLA12Pin)
SLA4052	9	120	3	2000		11	SIP12 with Fin (SLA12Pin)

### ● General-Purpose

Part Number	Circuit Count	V <sub>CE0</sub> (V)/ V <sub>DSS</sub> (V)	I <sub>c</sub> (A)/ I <sub>D</sub> (A)	h <sub>FE</sub> (min)	R <sub>Ds(ON)</sub> max (Ω)	Equivalent Circuit	Package
STA303A	3	100	4	100		12	SIP8Pin
STA412A	4	60	3	300		13	SIP10Pin
STA473A	4	100	2	2000		17	SIP10Pin
SMA4030	4	100	3	2000		15	SIP12Pin
STA403A	4	100	4	1000		17	SIP10Pin
SLA4030	4	100	4	2000		15	SIP12 with Fin (SLA12Pin)
SLA5037	4	100	10		0.08	14	SIP12 with Fin (SLA12Pin)
SLA4060	4	120	5	2000		15	SIP12 with Fin (SLA12Pin)
STA404A	4	200	3	1000		17	SIP10Pin
SLA5041	4	200	10		0.175	14	SIP12 with Fin (SLA12Pin)
SLA5085	5	60	5		0.22	16	SIP12 with Fin (SLA12Pin)

●Equivalent Circuit (for Sink Driver)

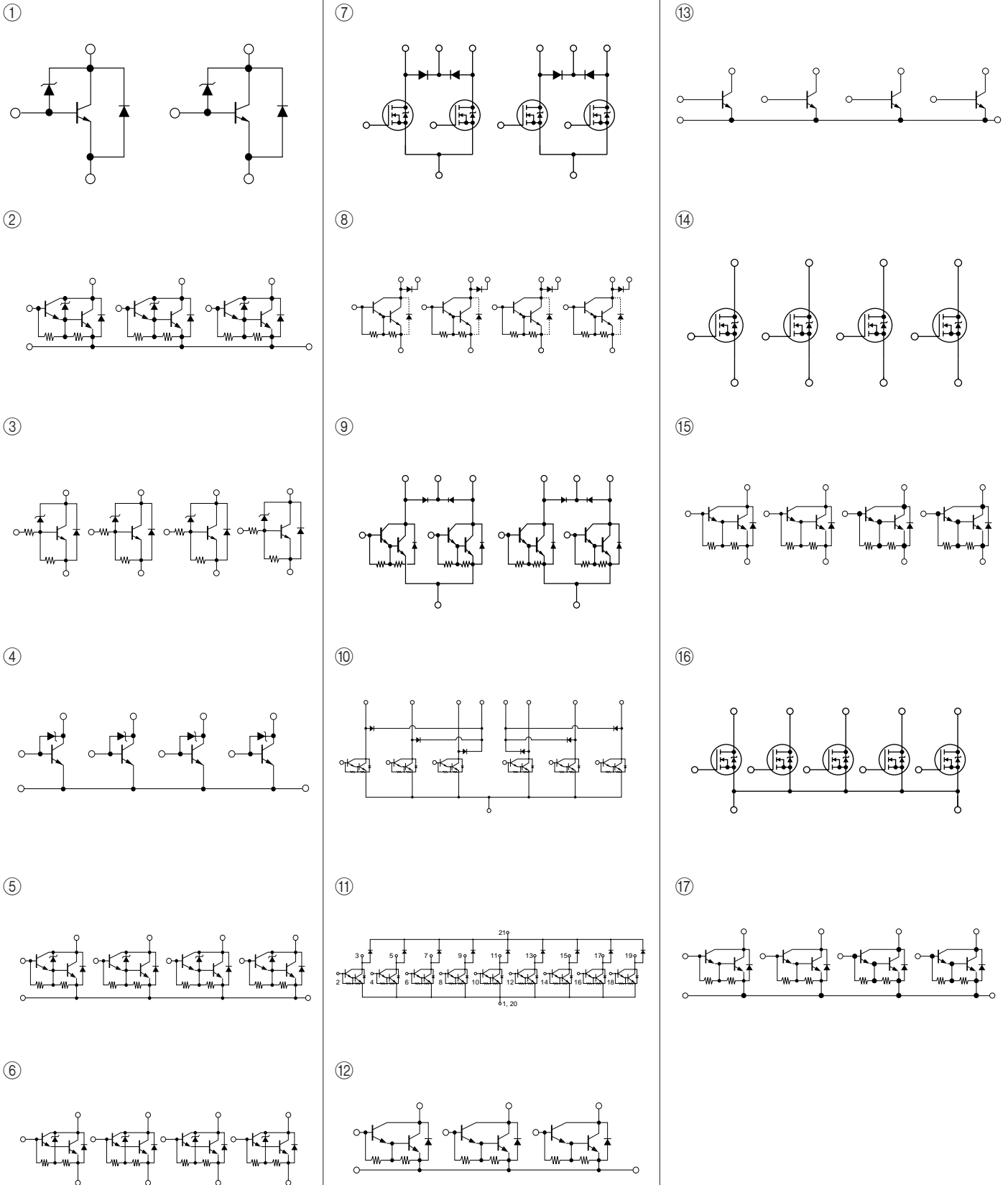

• SIP 8 (STA8Pin)

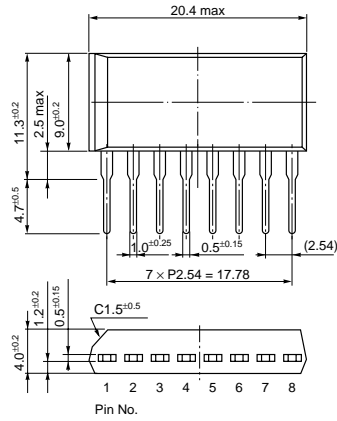

• SIP 10 (STA10Pin)

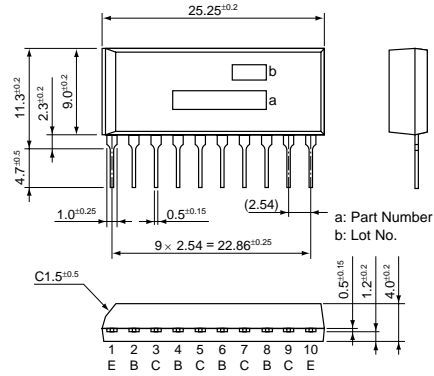

• PS 16 (Surface-Mount)

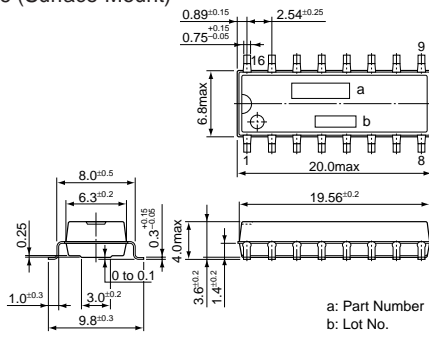

• SIP 12 (SMA12Pin)

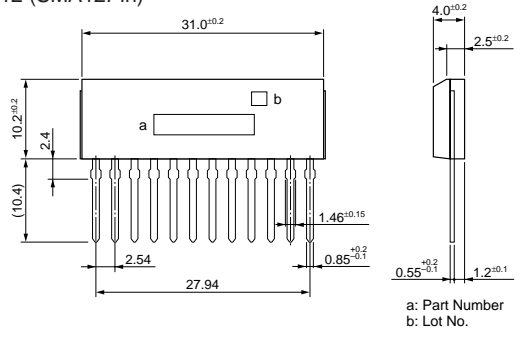

• SIP 15 (SMA15Pin)

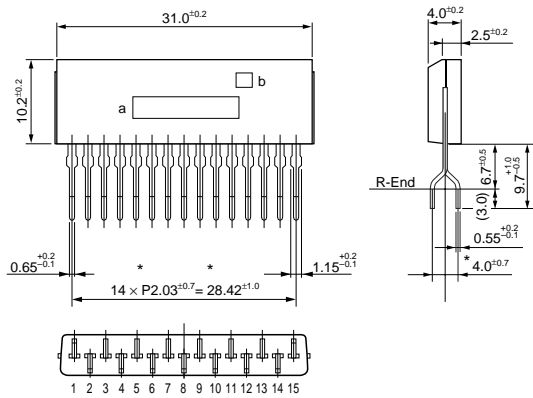

• SIP 12 with Fin (SLA12Pin)

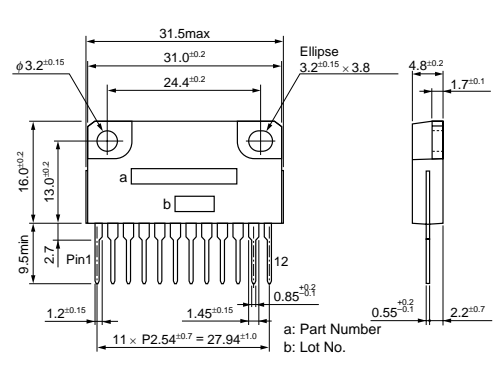

• SIP 15 with Fin (SLA15Pin)

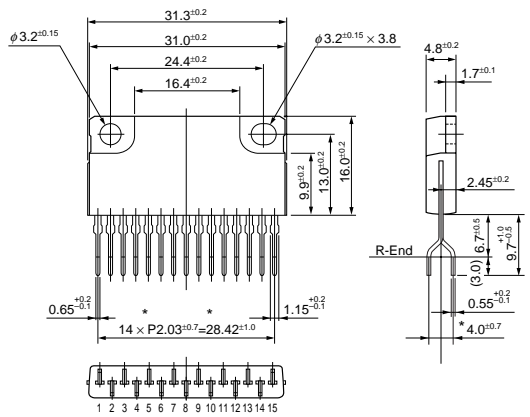

• SIP 21 with Fin (SLA21Pin)

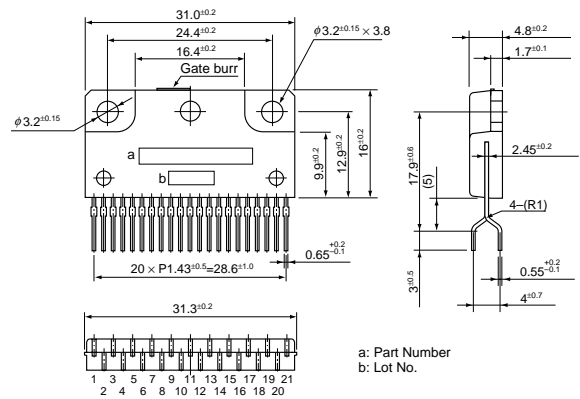

(Unit:mm)