

SI-3000ZD Series Surface-Mount, Low Dropout Voltage

Features

- Compact surface-mount package (TO263-5)
- Output current: 3.0A
- Low dropout voltage: $V_{DIF} \leq 0.6V$ (at $I_o = 3.0A$)
- Low circuit current at output OFF: $I_q(OFF) \leq 1\mu A$
- Built-in overcurrent and thermal protection circuits

Applications

- Secondary stabilized power supply (local power supply)

Absolute Maximum Ratings

($T_a=25^\circ C$)

Parameter	Symbol	Rated	Unit
DC Input Voltage	V_{IN}^{*1}	10	V
Output Control Terminal Voltage	V_c	6	V
DC Output Current	I_o^{*1}	3.0	A
Power Dissipation	P_D^{*3}	3	W
Junction Temperature	T_j	-30 to +125	$^\circ C$
Operating Ambient Temperature	T_{op}	-30 to +85	$^\circ C$
Storage Temperature	T_{stg}	-40 to +125	$^\circ C$
Thermal Resistance (Junction to Ambient Air)	θ_{ja}	33.3	$^\circ C/W$
Thermal Resistance (Junction to Case)	θ_{jc}	3	$^\circ C/W$

Recommended Operating Conditions

Parameter	Symbol	Rated	Unit	Remarks
Input Voltage	V_{IN}	*2 to 6^{*1}	V	
Output Current	I_o	0 to 3	A	
Operating Ambient Temperature	$T_{op(a)}$	-20 to +85	$^\circ C$	
Operating Junction Temperature	$T_{op(j)}$	-20 to +100	$^\circ C$	
Output Voltage Variable Range	V_{OAdj}	1.2 to 5	V	Only for SI-3011ZD. Refer to the block diagram.

*1: V_{IN} (max) and I_o (max) are restricted by the relation $P_D = (V_{IN} - V_o) \times I_o$.

*2: Set the input voltage to 2.4V or higher when setting the output voltage to 2.0V or lower (SI-3011ZD).

*3: When mounted on glass-epoxy board of 40 x 40mm (copper laminate area 100%).

Electrical Characteristics

($T_a=25^\circ C, V_c=2V$, unless otherwise specified)

Parameter	Symbol	Rated						Unit
		SI-3011ZD (Variable type)			SI-3033ZD			
		min.	typ.	max.	min.	typ.	max.	
Output Voltage (Reference Voltage V_{ADJ} for SI-3011ZD)	$V_o (V_{ADJ})$	1.078	1.100	1.122	3.234	3.300	3.366	V
	Conditions	$V_{IN}=V_o+1V, I_o=10mA$			$V_{IN}=5V, I_o=10mA$			
Line Regulation	ΔV_{OLINE}			10			10	mV
	Conditions	$V_{IN}=3.3$ to $5V, I_o=10mA (V_o=2.5V)$			$V_{IN}=4.5$ to $5.5V, I_o=10mA$			
Load Regulation	ΔV_{LOAD}			40			40	mV
	Conditions	$V_{IN}=3.3V, I_o=0$ to $3A (V_o=2.5V)$			$V_{IN}=5V, I_o=0$ to $3A$			
Dropout Voltage	V_{DIF}			0.6			0.6	V
	Conditions	$I_o=3A (V_o=2.5V)$			$I_o=3A$			
Quiescent Circuit Current	I_q		1	1.5		1	1.5	mA
	Conditions	$V_{IN}=V_o+1V, I_o=0A, V_c=2V$			$V_{IN}=5V, I_o=0A, V_c=2V$			
Circuit Current at Output OFF	$I_q(OFF)$			1			1	μA
	Conditions	$V_{IN}=V_o+1V, V_c=0V$			$V_{IN}=5V, V_c=0V$			
Temperature Coefficient of Output Voltage	$\Delta V_o/\Delta T_a$		± 0.3			± 0.3		mV/ $^\circ C$
	Conditions	$T_j=0$ to $100^\circ C$			$T_j=0$ to $100^\circ C$			
Ripple Rejection	R_{REJ}		60			60		dB
	Conditions	$V_{IN}=V_o+1V, f=100$ to $120Hz, I_o=0.1A$			$V_{IN}=5V, f=100$ to $120Hz, I_o=0.1A$			
Overcurrent Protection Starting Current ^{*2}	I_{S1}	3.2			3.2			A
	Conditions	$V_{IN}=V_o+1V$			$V_{IN}=5V$			
Vc Terminal	Control Voltage (Output ON) ^{*3}	V_c, IH	2		2			V
	Control Voltage (Output OFF) ^{*3}	V_c, IL		0.8		0.8		
	Control Current (Output ON)	I_c, IH		100		100		μA
	Control Current (Output OFF)	I_c, IL	-5	0		-5	0	μA
	Conditions	$V_c=2.7V$			$V_c=2.7V$			
	Conditions	$V_c=0V$			$V_c=0V$			

*1: Set the input voltage to 2.4V or higher when setting the output voltage to 2.0V or lower.

*2: I_{S1} is specified at the -5% drop point of output voltage V_o under the condition of Output Voltage parameter.

*3: Output is OFF when the output control terminal (Vc terminal) is open. Each input level is equivalent to LS-TTL level. Therefore, the device can be driven directly by LS-TTLs.

*4: These products cannot be used for the following applications because the built-in foldback-type overcurrent protection may cause errors during start-up stage.

- (1) Constant current load (2) Positive and negative power supply (3) Series-connected power supply (4) V_o adjustment by raising ground voltage

External Dimensions (TO263-5)

(Unit : mm)

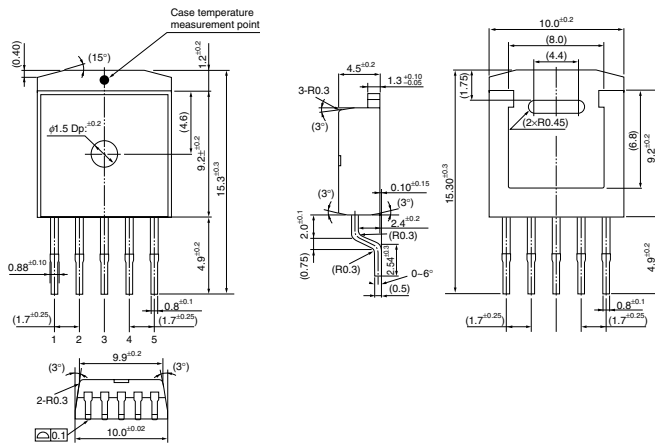

Pin Assignment

- ① V_c
- ② V_{IN}
- ③ GND (Common to the rear side of product)
- ④ V_O
- ⑤ Sense (ADJ for SI-3011ZD)

Plastic Mold Package Type
 Flammability: UL94V-0
 Product Mass: Approx. 1.48g

Block Diagram

SI-3011ZD

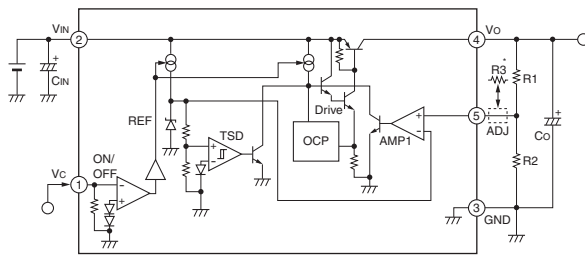

C_{IN}: Input capacitor (Approx. 10μF)
 C_O: Output capacitor (47μF or larger)
 The output voltage may oscillate if a low ESR type capacitor (such as a ceramic capacitor) is used for the output capacitor in the SI-3000ZD Series.

SI-3033ZD

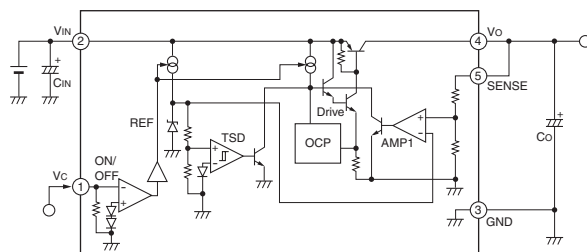

R₁, R₂: Output voltage setting resistors
 The output voltage can be set by connecting R₁ and R₂ as shown at left.
 The recommended value for R₂ is 10kΩ or 11kΩ.
 $R1 = (V_O - V_{ADJ}) / (V_{ADJ} / R2)$
 *: Insert R₃ in case of setting V_O to V_O ≤ 1.8V. The recommended value for R₃ is 10kΩ.

Reference Data

Copper Laminate Area (on Glass-Epoxy Board) vs. Thermal Resistance (from Junction to Ambient Temperature) (Typical Value)

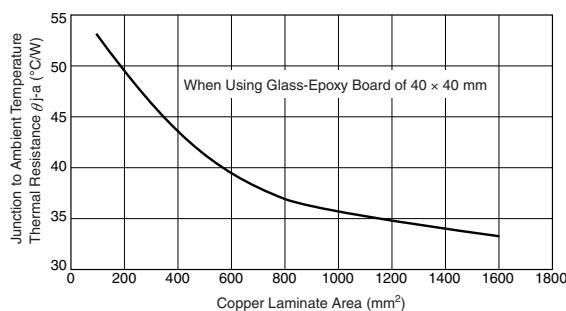

- A higher heat radiation effect can be achieved by enlarging the copper laminate area connected to the inner frame to which a monolithic IC is mounted.
- Obtaining the junction temperature
 Measure GND terminal temperature T_c with a thermocouple, etc. Then substitute this value in the following formula to obtain the junction temperature.

$$T_j = P_D \times \theta_{j-a} + T_c \quad P_D = (V_{IN} - V_O) \times I_{OUT}$$