

# SI-3000LSA Series Surface-Mount, Low Current Consumption, Low Dropout Voltage

## ■ Features

- Compact surface-mount package (SOP8)
- Output current: 1 A
- Low circuit current at output OFF:  $I_{q(OFF)} \leq 1 \mu\text{A}$  ( $V_C = 0 \text{ V}$ )
- Low dropout voltage:  $V_{DIF} \leq 0.8 \text{ V}$  (at  $I_O = 1 \text{ A}$ )  
 $V_{DIF} \leq 1.2 \text{ V}$  ( $I_O = 1 \text{ A}$ ) for SI-3018LSA
- 4 types of output voltages (1.8 V, 2.5 V, 3.3 V, 5.0 V) available
- Output ON/OFF control terminal voltage compatible with LS-TTL
- Built-in foldback-type-overcurrent and thermal protection circuits

## ■ Absolute Maximum Ratings

( $T_a = 25^\circ\text{C}$ )

Parameter	Symbol	Rated	Unit
DC Input Voltage	$V_{IN}$	16	V
Output control terminal voltage	$V_C$	$V_{IN}$	V
DC Output Current	$I_O$	1	A
Power Dissipation	$P_{D1}^{*1}$	1.16	W
	$P_{D2}^{*2}$	1.1	W
Junction Temperature	$T_J^{*3}$	-30 to +150	$^\circ\text{C}$
Operating Ambient Temperature	$T_{OP}$	-30 to +150	$^\circ\text{C}$
Storage Temperature	$T_{STG}$	-30 to +150	$^\circ\text{C}$
Thermal Resistance (Junction to Lead (pin 8))	$\theta_{J-L}$	36	$^\circ\text{C/W}$
Thermal Resistance (Junction to Ambient Air)	$\theta_{J-a}^{*2}$	100	$^\circ\text{C/W}$

\*1: When mounted on glass-epoxy board 56.5 × 56.5 mm (copper laminate area 100%).

\*2: When mounted on glass-epoxy board 40 × 40 mm (copper laminate area 100%).

\*3: Thermal protection circuits may be activated if the junction temperature exceeds 135 $^\circ\text{C}$ .

## ■ Applications

- Auxiliary power supplies for PC
- Battery-driven electronic equipment

## ■ Recommended Operating Conditions

Parameter	Symbol	Ratings				Unit
		SI-3018LSA	SI-3025LSA	SI-3033LSA	SI-3050LSA	
DC Input Voltage Range	$V_{IN}$	3.1 to 3.5 <sup>*1</sup>	<sup>*2</sup> to 3.5 <sup>*1</sup>	<sup>*2</sup> to 5.2 <sup>*1</sup>	<sup>*2</sup> to 8.0	V
DC Output Current Range	$I_O$	0 to 1				A
Operating Junction Temperature	$T_{JP}$	-20 to +125				$^\circ\text{C}$
Operating Ambient Temperature	$T_{AP}$	-30 to +85				$^\circ\text{C}$

\*1:  $V_{IN}$  (max) and  $I_O$  (max) are restricted by the relation  $P_D = (V_{IN} - V_O) \times I_O$ .

Please calculate these values referring to the reference data on page 69.

\*2: Refer to the Dropout Voltage parameter.

## ■ Electrical Characteristics

( $T_a = 25^\circ\text{C}$ ,  $V_C = 2\text{V}$ , unless otherwise specified)

Parameter	Symbol	Ratings												Unit
		SI-3018LSA			SI-3025LSA			SI-3033LSA			SI-3050LSA			
		min.	typ.	max.	min.	typ.	max.	min.	typ.	max.	min.	typ.	max.	
Output Voltage	$V_O$	1.764	1.800	1.836	2.450	2.500	2.550	3.234	3.300	3.366	4.90	5.00	5.10	V
	Conditions	$V_{IN} = 3.3\text{V}$ , $I_O = 0.5\text{A}$			$V_{IN} = 3.3\text{V}$ , $I_O = 0.5\text{A}$			$V_{IN} = 5\text{V}$ , $I_O = 0.5\text{A}$			$V_{IN} = 6\text{V}$ , $I_O = 0.5\text{A}$			
Dropout Voltage	$V_{DIF}$	-			0.4			0.4			0.4			V
	Conditions	-			$I_O \leq 0.5\text{A}$			$I_O \leq 0.5\text{A}$			$I_O \leq 0.5\text{A}$			
	Conditions	0.6	1.2			0.8		0.8		0.8		0.8		
Line Regulation	$\Delta V_{LINE}$	2			2			3			3			mV
	Conditions	$V_{IN} = 3.1$ to $3.5\text{V}$ , $I_O = 0.3\text{A}$			$V_{IN} = 3.1$ to $3.5\text{V}$ , $I_O = 0.3\text{A}$			$V_{IN} = 4.5$ to $5.5\text{V}$ , $I_O = 0.3\text{A}$			$V_{IN} = 6$ to $7\text{V}$ , $I_O = 0.3\text{A}$			
Load Regulation	$\Delta V_{LOAD}$	10			10			10			10			mV
	Conditions	$V_{IN} = 3.3\text{V}$ , $I_O = 0$ to $1\text{A}$			$V_{IN} = 3.3\text{V}$ , $I_O = 0$ to $1\text{A}$			$V_{IN} = 5\text{V}$ , $I_O = 0$ to $1\text{A}$			$V_{IN} = 6\text{V}$ , $I_O = 0$ to $1\text{A}$			
Temperature Coefficient of Output Voltage	$\Delta V_O / \Delta T_a$	$\pm 0.3$			$\pm 0.3$			$\pm 0.3$			$\pm 0.5$			mV/ $^\circ\text{C}$
	Conditions	$V_{IN} = 3.3\text{V}$ , $I_O = 5\text{mA}$ , $T_J = 0$ to $100^\circ\text{C}$			$V_{IN} = 3.3\text{V}$ , $I_O = 5\text{mA}$ , $T_J = 0$ to $100^\circ\text{C}$			$V_{IN} = 5\text{V}$ , $I_O = 5\text{mA}$ , $T_J = 0$ to $100^\circ\text{C}$			$V_{IN} = 6\text{V}$ , $I_O = 5\text{mA}$ , $T_J = 0$ to $100^\circ\text{C}$			
Ripple Rejection	$R_{REJ}$	60			57			55			55			dB
	Conditions	$V_{IN} = 3.3\text{V}$ , $f = 100$ to $120\text{Hz}$			$V_{IN} = 3.3\text{V}$ , $f = 100$ to $120\text{Hz}$			$V_{IN} = 5\text{V}$ , $f = 100$ to $120\text{Hz}$			$V_{IN} = 6\text{V}$ , $f = 100$ to $120\text{Hz}$			
Quiescent Circuit Current	$I_q$	1.7			1.7			1.7			1.7			mA
	Conditions	$V_{IN} = 3.3\text{V}$ , $I_O = 0\text{A}$			$V_{IN} = 3.3\text{V}$ , $I_O = 0\text{A}$			$V_{IN} = 5\text{V}$ , $I_O = 0\text{A}$			$V_{IN} = 6\text{V}$ , $I_O = 0\text{A}$			
Circuit Current at Output OFF	$I_{q(OFF)}$	1			1			1			1			$\mu\text{A}$
	Conditions	$V_{IN} = 3.3\text{V}$ , $I_O = 0\text{A}$ , $V_C = 0\text{V}$			$V_{IN} = 3.3\text{V}$ , $I_O = 0\text{A}$ , $V_C = 0\text{V}$			$V_{IN} = 5\text{V}$ , $I_O = 0\text{A}$ , $V_C = 0\text{V}$			$V_{IN} = 6\text{V}$ , $I_O = 0\text{A}$ , $V_C = 0\text{V}$			
Overcurrent Protection Starting Current <sup>*1,3</sup>	$I_{S1}$	1.2			1.2			1.2			1.2			A
	Conditions	$V_{IN} = 3.3\text{V}$			$V_{IN} = 3.3\text{V}$			$V_{IN} = 5\text{V}$			$V_{IN} = 6\text{V}$			
$V_C$ Terminal	Control Voltage (Output ON) <sup>*2</sup>	$V_C, IH$	2.0		2.0		2.0		2.0		2.0		V	
	Control Voltage (Output OFF) <sup>*2</sup>	$V_C, IL$	0.8		0.8		0.8		0.8		0.8			
	Control Current (Output ON)	$I_C, IH$	40		40		40		40		40			
	Conditions	$V_C = 2\text{V}$												
	Control Current (Output OFF)	$I_C, IL$	0		0		0		0		0			
Conditions	$V_C = 0\text{V}$													

\*1:  $I_{S1}$  is specified at the 5% drop point of output voltage  $V_O$  on the condition that  $V_{IN} = 3.3 \text{ V}$  (5 V for SI-3033LSA), and  $I_O = 0.5 \text{ A}$ .

\*2: Output is OFF when the output control terminal  $V_C$  is open. Each input level is equivalent to LS-TTL level. Therefore, the device can be driven directly by LS-TTLs.

\*3: These products cannot be used in the following applications. Because these applications require a certain current at start-up and so the built-in foldback-type overcurrent protection may cause errors during start-up stage.

(1) Constant current load (2) Positive and negative power supply (3) Series-connected power supply (4)  $V_O$  adjustment by raising ground voltage

External Dimensions (SOP8)

(Unit : mm)

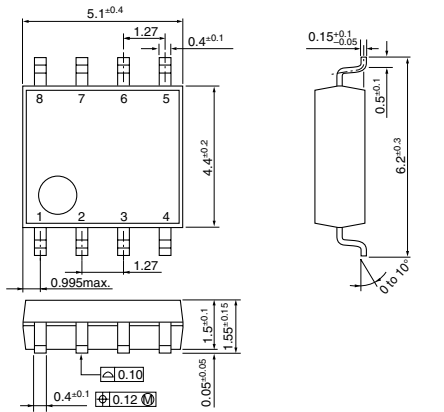

Pin Assignment

- ① VIN
- ② NC (Leave open)
- ③ VIN
- ④ Vc
- ⑤ GND
- ⑥ GND
- ⑦ Vo
- ⑧ Vo

Plastic Mold Package Type  
 Flammability: UL94V-0  
 Product Mass: Approx. 0.1g

Block Diagram

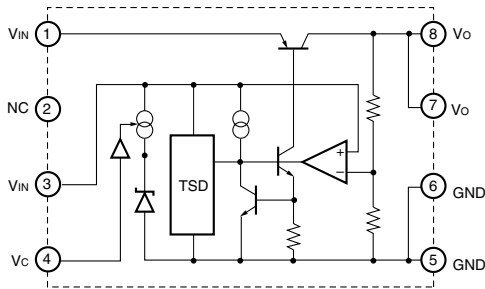

Typical Connection Diagram

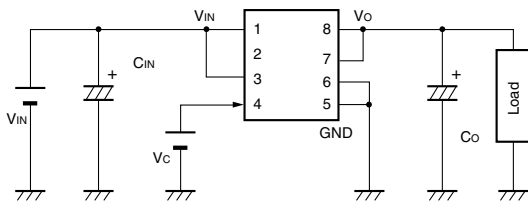

Co: Output capacitor (22  $\mu$ F or larger)

CIN: Input capacitor (10  $\mu$ F)

This capacitor is required in the case of an inductive input line or long wiring.

Tantalum capacitors are recommended for CIN and Co, particularly at low temperatures.

\* Leave pin 2 open.

Reference Data

PCB Copper Laminate Area vs. Junction to Ambient Air Thermal Resistance

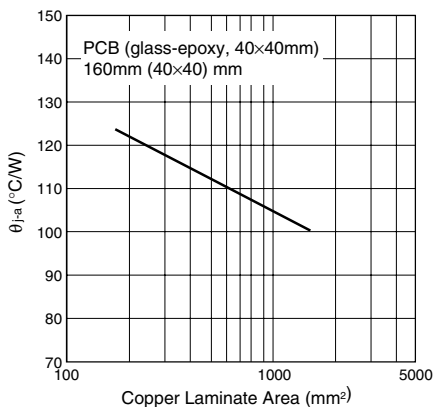

Allowable Output Current (vs. VIN-VOUT Voltage Difference) VIN-Io max

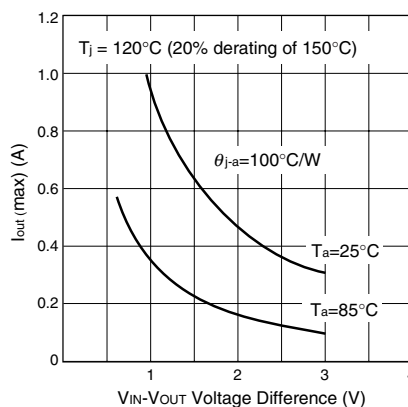

The inner frame stage, on which the PTR is mounted, is directly connected to the Vout pin.

Therefore, enlarging the copper laminate area around the Vout pin is really effective for a heat radiation.