

4-2 Fast Recovery Diodes

V _{RM} (V)	I _F (AV) (A) <small>Values in parentheses are for the products with heatsinks</small>	Package Axial <small>(Body Diameter/Lead Diameter)</small>	Part Number	I _{FSM} (A)	T _j (°C)	T _{stg} (°C)	V _F (V) max	I _F (A)	I _R (μA)	I _{R(H)} (μA)	T _a (°C)	trr(1)	I _F /I _{RP}	trr(2)	I _F /I _{RP}	Rth(j-l) Rth(j-c) (°C/W)	Mass (g)
				50Hz <small>Single Half Sine Wave</small>				V _R =V _{RM} max	V _R =V _{RM} max	(μs)		(mA)	(μs)	(mA)			
600	0.25	Axial(φ4.0/φ0.78)	RU 1A	15	-40 to +150	2.5	0.25	10	200	100	0.4	10/10	0.18	10/20	15	0.4	
	0.5	Axial(φ2.4/φ0.6)	AU01A	15	-40 to +150	1.7	0.5	10	150	100	0.4	10/10	0.18	10/20	22	0.13	
	0.6	Axial(φ4.0/φ0.78)	RF 1A	15	-40 to +150	2.0	0.6	10	200	100	0.4	10/10	0.18	10/20	15	0.4	
	0.6	Axial(φ2.4/φ0.6)	AS01A	20	-40 to +150	1.5	0.6	10	50	100	1.5	10/10	0.6	10/20	22	0.13	
	0.6	Axial(φ4.0/φ0.78)	RH 1A	35	-40 to +150	1.3	0.6	5	70	150	4	10/10	1.3	10/20	15	0.4	
	0.7	Axial(φ2.7/φ0.6)	ES01A	30	-40 to +150	2.5	0.8	10	200	100	1.5	10/10	0.6	10/20	20	0.2	
	0.7	Axial(φ4.0/φ0.78)	RS 1A	30	-40 to +150	2.5	0.8	10	200	100	1.5	10/10	0.6	10/20	15	0.4	
	0.8	Axial(φ2.4/φ0.6)	AU02A	25	-40 to +150	1.3	0.8	10	250	100	0.4	10/10	0.18	10/20	22	0.13	
	1.0	Axial(φ2.7/φ0.6)	EU02A	15	-40 to +150	1.4	1.0	10	300	100	0.4	10/10	0.18	10/20	20	0.2	
	1.0	Axial(φ2.7/φ0.78)	EU 2A	15	-40 to +150	1.4	1.0	10	300	100	0.4	10/10	0.18	10/20	17	0.3	
	1.0	Axial(φ4.0/φ0.78)	RU 2	20	-40 to +150	1.5	1.0	10	300	100	0.4	10/10	0.18	10/20	15	0.4	
	1.1	Axial(φ4.0/φ0.78)	RU 2AM	20	-40 to +150	1.2	1.1	10	300	100	0.4	10/10	0.18	10/20	15	0.4	
	1.5	Axial(φ4.0/φ0.98)	RU 3A	20	-40 to +150	1.5	1.5	10	400	100	0.4	10/10	0.18	10/20	12	0.6	
	1.5	Axial(φ4.0/φ0.78)	RU 20A	50	-40 to +150	1.1	1.5	10	350	100	0.4	10/10	0.18	10/20	15	0.4	
	1.5	Axial(φ4.0/φ0.98)	RU 3AM	50	-40 to +150	1.1	1.5	10	350	100	0.4	10/10	0.18	10/20	12	0.6	
	1.5(3.0)	Axial(φ6.5/φ1.4)	RU 4A	50	-40 to +150	1.5	3.0	10	300	100	0.4	10/10	0.18	10/20	8	1.2	
	2.0(3.5)	Axial(φ6.5/φ1.4)	RU 4AMS	70	-40 to +150	1.3	3.5	10	300	100	0.4	100/100	0.18	100/200	8	1.2	
	5.0	TO-220F2Pin	FMU-G16S	30	-40 to +150	1.25	5.0	50	500	100	0.4	100/100	0.18	100/200	4.0	2.1	
5.0	TO-220F(Center-tap)	FMU-16S, R	30	-40 to +150	1.5	2.5	50	500	100	0.4	100/100	0.18	100/200	4.0	2.1		
10	TO-220F(Center-tap)	FMU-26S, R	40	-40 to +150	1.5	5.0	50	500	100	0.4	100/100	0.18	100/200	4.0	2.1		
10	TO-220F2Pin	FMU-G26S	40	-40 to +150	1.35	10	50	500	100	0.4	100/100	0.18	100/200	4.0	2.1		
800	0.25	Axial(φ4.0/φ0.78)	RU 1B	15	-40 to +150	2.5	0.25	10	200	100	0.4	10/10	0.18	10/20	15	0.4	
	0.6	Axial(φ4.0/φ0.78)	RF 1B	15	-40 to +150	2.0	0.6	10	200	100	0.4	10/10	0.18	10/20	15	0.4	
	0.6	Axial(φ4.0/φ0.78)	RH 1B	35	-40 to +150	1.3	0.6	5	70	150	4	10/10	1.3	10/20	15	0.4	
	0.7	Axial(φ4.0/φ0.78)	RS 1B	30	-40 to +150	2.5	0.8	10	200	100	1.5	10/10	0.6	10/20	20	0.4	
	1.0	Axial(φ4.0/φ0.78)	RU 2B	20	-40 to +150	1.5	1.0	10	300	100	0.4	10/10	0.18	10/20	15	0.4	
	1.1	Axial(φ4.0/φ0.98)	RU 3B	20	-40 to +150	1.5	1.0	10	400	100	0.4	10/10	0.18	10/20	12	0.6	
	1.5(3.0)	Axial(φ6.5/φ1.4)	RU 4B	50	-40 to +150	1.6	3.0	10	500	100	0.4	10/10	0.18	10/20	8	1.2	
1000	0.2	Axial(φ4.0/φ0.78)	RU 1C	15	-40 to +150	3.0	0.25	10	200	100	0.4	10/10	0.18	10/20	15	0.4	
	0.6	Axial(φ4.0/φ0.78)	RH 1C	35	-40 to +150	1.3	0.6	5	70	150	4	10/10	1.3	10/20	15	0.4	
	0.8	Axial(φ4.0/φ0.78)	RU 2C	20	-40 to +150	1.5	1.0	10	300	100	0.4	10/10	0.18	10/20	15	0.4	
	1.5	Axial(φ4.0/φ0.98)	RU 3C	20	-40 to +150	2.5	1.5	10	400	100	0.4	10/10	0.18	10/20	12	0.6	
	1.5(2.5)	Axial(φ6.5/φ1.4)	RU 4C	50	-40 to +150	1.6	3.0	50	500	100	0.4	100/100	0.18	100/200	8	1.2	
1300	1.0	Axial(φ4.0/φ0.98)	RH 2D	60	-40 to +150	1.0	1.0	10	500	100	4	10/10	1.3	100/200	12	0.6	
	1.2(1.5)	Axial(φ6.5/φ1.4)	RU 4D	50	-40 to +150	1.8	1.5	50	500	100	0.4	500/500	0.18	500/1000	8	1.2	
	1.5(2.5)	Axial(φ6.5/φ1.4)	RU 4DS	50	-40 to +150	1.8	3.0	50	500	100	0.4	500/500	0.18	500/1000	8	1.2	
1500	0.5	Axial(φ2.7/φ0.6)	ES01F	20	-40 to +150	2.0	0.5	10	200	100	1.5	10/10	0.6	10/20	20	0.2	
	0.5	Axial(φ2.7/φ0.78)	ES 1F	20	-40 to +150	2.0	0.5	10	200	100	1.5	10/10	0.6	10/20	17	0.3	
	1.0	Axial(φ4.0/φ0.98)	RH 2F	60	-40 to +150	1.0	1.0	10	500	100	4	10/10	1.3	100/200	12	0.6	
	2.0	Axial(φ5.2/φ1.2)	RS 3FS	50	-40 to +150	1.1	3.0	50	500	100	2	100/100	0.8	100/200	10	1.0	
	2.0	Axial(φ5.2/φ1.2)	RP 3F	50	-40 to +150	1.7	2.0	50	500	100	0.7	500/500	0.3	500/1000	10	1.0	
	2.5	Axial(φ5.2/φ1.2)	RH 3F	50	-40 to +150	1.3	2.5	50	500	100	4	100/100	1.3	100/200	10	1.0	
	1.5(2.5)	Axial(φ6.5/φ1.4)	RS 4FS	50	-40 to +150	1.5	3.0	50	500	100	1	100/100	0.4	100/200	8	1.2	
	2.5	Axial(φ6.5/φ1.4)	RH 4F	50	-40 to +150	1.5	2.5	10	350	100	4	100/100	1.3	100/200	8	1.2	
	5.0	TO-220F2Pin	FMQ-G1FS	50	-40 to +150	5.0	5.0	50	500	150	0.7	500/500	0.3	500/1000	4.0	2.1	
	10	TO-220F2Pin	FMQ-G2FS	50	-40 to +150	2.8	10	50	500	150(Tj)	0.5	500/500	0.2	500/1000	4.0	2.1	
	10	TO-220F2Pin	FMU-G2FS	50	-40 to +150	1.6	10	50	6000	150(Tj)	0.6	500/500	0.25	500/1000	4.0	2.1	
	10	TO-220F2Pin	FMQ-G2FLS	50	-40 to +150	1.8	10	50	500	150(Tj)	1.2	500/500	0.4	500/1000	4.0	2.1	
10	TO-220F2Pin	FMQ-G2FMS	50	-40 to +150	2.4	10	50	500	150	0.5	500/500	0.25	500/1000	4.0	2.1		
10	TO-3PF2Pin	FMQ-G5FMS	50	-40 to +150	2.4	10	50	500	100	0.5	500/500	0.2	500/1000	2	6.5		
10	TO-3PF2Pin	FMV-G5FS	50	-40 to +150	1.5	10	50	700	100	2.0	500/500	0.8	500/1000	2	6.5		
1600	2.5	Axial(φ5.2/φ1.2)	RH 3G	50	-40 to +150	1.3	2.5	50	500	100	4	100/100	1.3	100/200	10	1.0	
1700	10	TO-3PF2Pin	FMQ-G5GS	50	-40 to +150	2.7	10	100	500	100	0.5	500/500	0.2	500/1000	2	6.5	
1800	8.0	TO-3PF2Pin	FMP-G5HS	50	-40 to +150	2.0	8	25	250	100	1.0	500/500	0.4	500/1000	2	6.5	
	10	TO-3PF2Pin	FMR-G5HS	50	-40 to +150	1.6	10	20	200	100	1.8	500/500	0.7	500/1000	2	6.5	
2000	0.2	Axial(φ4.0/φ0.78)	RC 2	20	-40 to +150	2.0	0.2	10	300	100	4.0	10/10	1.3	10/20	15	0.4	

• No. 13 Axial ($\phi 4.0/\phi 0.78$)

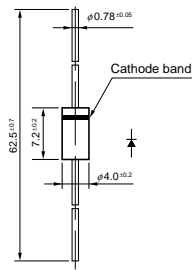

• No. 14 Axial ($\phi 4.0/\phi 0.98$)

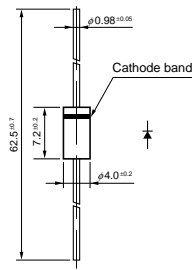

• No. 15 Axial ($\phi 5.2/\phi 1.2$)

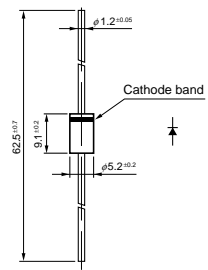

• No. 16 Axial ($\phi 6.5/\phi 1.4$)

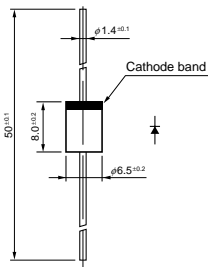

• No. 17 Axial ($\phi 10.0/\phi 1.3$)

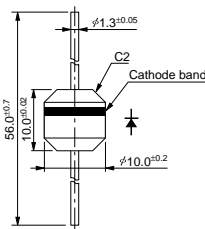

• No. 18 TO-220F (Two Elements)

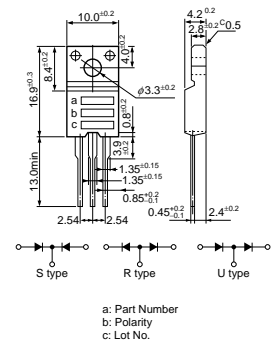

• No. 19 TO-220F (Center-tap)

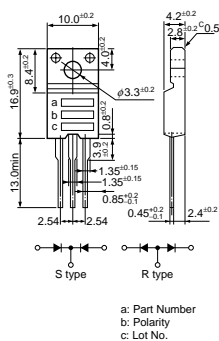

• No. 20 TO-220F2Pin

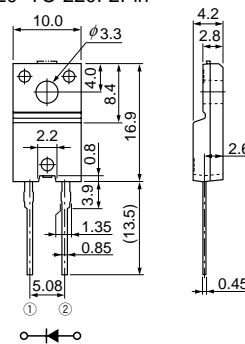

• No. 21 TO-220F2Pin (Two Elements)

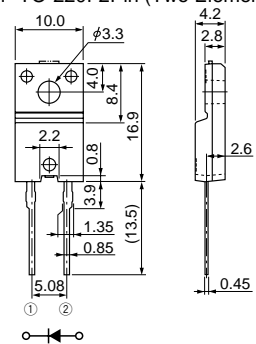

• No. 22 TO-3PF

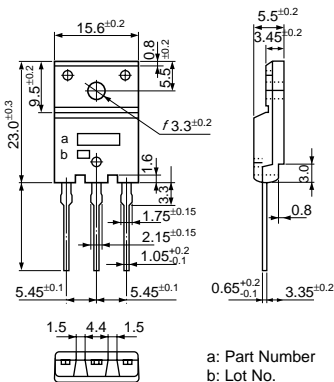

• No. 23 TO-3PF2Pin

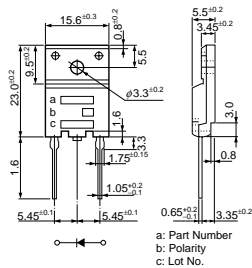

• No. 24 RBV-60

