

4-2 Fast Recovery Diodes

●Thru-Hole

| V _{RM} (V) | I _F (AV) (A) <small>Values in parentheses are for the products with heatsinks</small> | Package Axial <small>Body Diameter/Lead Diameter</small> | Part Number | I _{FSM} (A) <small>50Hz Single Half Sine Wave</small> | T _j (°C) | T _{stg} (°C) | V _F (V) max | I _F (A) | I _R (μA) | I _R (H) (μA) | T _j (°C) | trr ⁽¹⁾ (μs) | I _F /I _{RP} (mA) | trr ⁽²⁾ (μs) | I _F /I _{RP} (mA) | R _{th(j-l)} R _{th(j-c)} (°C/W) | Mass (g) |
|------------------------|--|--|----------------|--|------------------------|--------------------------|------------------------------|-----------------------|--|--|------------------------|----------------------------|---|----------------------------|---|--|-------------|
| | | | | | | | | | V _R =V _{RM} max | V _R =V _{RM} max | | | | | | | |
| 200 | 0.5 | Axial(φ2.7/φ0.6) | EU01Z | 15 | -40 to +150 | 1.0 | 0.5 | 10 | 150 | 100(Ta) | 0.4 | 10/10 | 0.18 | 10/20 | 20 | 0.2 | |
| | 0.5 | Axial(φ2.7/φ0.78) | EU 1Z | 15 | -40 to +150 | 1.0 | 0.5 | 10 | 150 | 100(Ta) | 0.4 | 10/10 | 0.18 | 10/20 | 17 | 0.3 | |
| | 0.5 | Axial(φ2.4/φ0.6) | AU01Z | 15 | -40 to +150 | 1.7 | 0.5 | 10 | 150 | 100(Ta) | 0.4 | 10/10 | 0.18 | 10/20 | 22 | 0.13 | |
| | 0.6 | Axial(φ4.0/φ0.78) | RH 1Z | 35 | -40 to +150 | 1.3 | 0.6 | 5.0 | 70 | 150(Ta) | 4.0 | 10/10 | 1.3 | 10/20 | 15 | 0.4 | |
| | 0.7 | Axial(φ2.7/φ0.78) | ES 1Z | 30 | -40 to +150 | 2.5 | 0.8 | 10 | 200 | 100(Ta) | 1.5 | 10/10 | 0.6 | 10/20 | 17 | 0.3 | |
| | 0.8 | Axial(φ2.4/φ0.6) | AU02Z | 25 | -40 to +150 | 1.3 | 0.8 | 10 | 250 | 100 | 0.4 | 10/10 | 0.18 | 10/20 | 22 | 0.13 | |
| | 1.0 | Axial(φ2.7/φ0.6) | EU02Z | 15 | -40 to +150 | 1.4 | 1.0 | 10 | 300 | 100 | 0.4 | 10/10 | 0.18 | 10/20 | 20 | 0.2 | |
| | 1.0 | Axial(φ2.7/φ0.78) | EU 2Z | 15 | -40 to +150 | 1.4 | 1.0 | 10 | 3000 | 150 | 0.4 | 10/10 | 0.18 | 10/20 | 17 | 0.3 | |
| | 1.0 | Axial(φ4.0/φ0.78) | RU 2Z | 20 | -40 to +150 | 1.5 | 1.0 | 10 | 300 | 100(Ta) | 0.4 | 10/10 | 0.18 | 10/20 | 15 | 0.4 | |
| | 3.5 | Axial(φ6.5/φ1.4) | RU 4Z | 70 | -40 to +150 | 1.3 | 3.5 | 10 | 300 | 100 | 0.4 | 10/10 | 0.18 | 10/20 | 8.0 | 1.2 | |
| 5.0 | TO-220F(Center-tap) | FMU-12S, R | 30 | -40 to +150 | 1.5 | 2.5 | 50 | 500 | 100(Ta) | 0.4 | 100/100 | 0.18 | 100/200 | 4.0 | 2.1 | | |
| 10 | TO-220F(Center-tap) | FMU-22S, R | 40 | -40 to +150 | 1.5 | 5.0 | 50 | 3000 | 150 | 0.4 | 100/100 | 0.18 | 100/200 | 4.0 | 2.1 | | |
| 400 | 0.25 | Axial(φ2.7/φ0.6) | EU01 | 15 | -40 to +150 | 2.5 | 0.25 | 10 | 150 | 100(Ta) | 0.4 | 10/10 | 0.18 | 10/20 | 20 | 0.2 | |
| | 0.25 | Axial(φ2.7/φ0.78) | EU 1 | 15 | -40 to +150 | 2.5 | 0.25 | 10 | 150 | 100(Ta) | 0.4 | 10/10 | 0.18 | 10/20 | 17 | 0.3 | |
| | 0.25 | Axial(φ4.0/φ0.78) | RU 1 | 15 | -40 to +150 | 2.5 | 0.25 | 10 | 200 | 100(Ta) | 0.4 | 10/10 | 0.18 | 10/20 | 15 | 0.4 | |
| | 0.5 | Axial(φ2.4/φ0.6) | AU01 | 15 | -40 to +150 | 1.7 | 0.5 | 10 | 150 | 100(Ta) | 0.4 | 10/10 | 0.18 | 10/20 | 22 | 0.13 | |
| | 0.6 | Axial(φ2.4/φ0.6) | AS01 | 20 | -40 to +150 | 1.5 | 0.6 | 10 | 50 | 100 | 1.5 | 10/10 | 0.6 | 10/20 | 22 | 0.13 | |
| | 0.6 | Axial(φ2.7/φ0.78) | EH 1 | 30 | -40 to +150 | 1.35 | 0.6 | 10 | 200 | 100(Ta) | 4.0 | 10/10 | 1.3 | 10/20 | 17 | 0.3 | |
| | 0.7 | Axial(φ2.7/φ0.78) | ES 1 | 30 | -40 to +150 | 2.5 | 0.8 | 10 | 200 | 100(Ta) | 1.5 | 10/10 | 0.6 | 10/20 | 20 | 0.2 | |
| | 0.8 | Axial(φ2.4/φ0.6) | AU02 | 25 | -40 to +150 | 1.3 | 0.8 | 10 | 250 | 100 | 0.4 | 10/10 | 0.18 | 10/20 | 22 | 0.13 | |
| | 1.0 | Axial(φ2.7/φ0.6) | EU02 | 15 | -40 to +150 | 1.4 | 1.0 | 10 | 300 | 100 | 0.4 | 10/10 | 0.18 | 10/20 | 20 | 0.2 | |
| | 1.0 | Axial(φ2.7/φ0.78) | EU 2 | 15 | -40 to +150 | 1.4 | 1.0 | 10 | 300 | 100 | 0.4 | 10/10 | 0.18 | 10/20 | 17 | 0.3 | |
| | 1.1 | Axial(φ4.0/φ0.78) | RU 2M | 20 | -40 to +150 | 1.2 | 1.1 | 10 | 300 | 100 | 0.4 | 10/10 | 0.18 | 10/20 | 15 | 0.4 | |
| | 1.5 | Axial(φ4.0/φ0.98) | RU 3 | 20 | -40 to +150 | 1.5 | 1.5 | 10 | 400 | 100 | 0.4 | 10/10 | 0.18 | 10/20 | 12 | 0.6 | |
| | 1.5 | Axial(φ4.0/φ0.98) | RU 3M | 50 | -40 to +150 | 1.1 | 1.5 | 10 | 350 | 100 | 0.4 | 10/10 | 0.18 | 10/20 | 12 | 0.6 | |
| | 1.5(3.0) | Axial(φ6.5/φ1.4) | RU 4 | 50 | -40 to +150 | 1.5 | 3.0 | 10 | 300 | 100(Ta) | 0.4 | 10/10 | 0.18 | 10/20 | 8.0 | 1.2 | |
| 2.0(3.5) | Axial(φ6.5/φ1.4) | RU 4M | 70 | -40 to +150 | 1.3 | 3.5 | 10 | 300 | 100 | 0.4 | 100/100 | 0.18 | 100/200 | 8.0 | 1.2 | | |
| 5.0 | TO-220F(Center-tap) | FMU-14S, R | 30 | -40 to +150 | 1.5 | 2.5 | 50 | 500 | 100(Ta) | 0.4 | 100/100 | 0.18 | 100/200 | 4.0 | 2.1 | | |
| 10 | TO-220F(Center-tap) | FMU-24S, R | 40 | -40 to +150 | 1.5 | 5.0 | 50 | 3000 | 150 | 0.4 | 100/100 | 0.18 | 100/200 | 4.0 | 2.1 | | |
| 600 | 0.25 | Axial(φ4.0/φ0.78) | RU 1A | 15 | -40 to +150 | 2.5 | 0.25 | 10 | 150 | 100 | 0.4 | 10/10 | 0.18 | 10/20 | 15 | 0.4 | |
| | 0.5 | Axial(φ2.4/φ0.6) | AU01A | 15 | -40 to +150 | 1.7 | 0.5 | 10 | 150 | 100(Ta) | 0.4 | 10/10 | 0.18 | 10/20 | 22 | 0.13 | |
| | 0.6 | Axial(φ4.0/φ0.78) | RF 1A | 15 | -40 to +150 | 2.0 | 0.6 | 10 | 200 | 100(Ta) | 0.4 | 10/10 | 0.18 | 10/20 | 15 | 0.4 | |
| | 0.6 | Axial(φ2.4/φ0.6) | AS01A | 20 | -40 to +150 | 1.5 | 0.6 | 10 | 50 | 100 | 1.5 | 10/10 | 0.6 | 10/20 | 22 | 0.13 | |
| | 0.6 | Axial(φ4.0/φ0.78) | RH 1A | 35 | -40 to +150 | 1.3 | 0.6 | 5.0 | 70 | 150(Ta) | 4.0 | 10/10 | 1.3 | 10/20 | 15 | 0.4 | |
| | 0.7 | Axial(φ2.7/φ0.6) | ES01A | 20 | -40 to +150 | 3.0 | 0.8 | 10 | 200 | 100(Ta) | 1.5 | 10/10 | 0.6 | 10/20 | 20 | 0.2 | |
| | 0.7 | Axial(φ4.0/φ0.78) | RS 1A | 30 | -40 to +150 | 2.5 | 0.8 | 10 | 2000 | 150 | 1.5 | 10/10 | 0.6 | 10/20 | 15 | 0.4 | |
| | 0.8 | Axial(φ2.4/φ0.6) | AU02A | 25 | -40 to +150 | 1.3 | 0.8 | 10 | 250 | 100(Ta) | 0.4 | 10/10 | 0.18 | 10/20 | 22 | 0.13 | |
| | 1.0 | Axial(φ2.7/φ0.6) | EU02A | 15 | -40 to +150 | 1.4 | 1.0 | 10 | 300 | 100 | 0.4 | 10/10 | 0.18 | 10/20 | 20 | 0.2 | |
| | 1.0 | Axial(φ2.7/φ0.78) | EU 2A | 15 | -40 to +150 | 1.4 | 1.0 | 10 | 300 | 100(Ta) | 0.4 | 10/10 | 0.18 | 10/20 | 17 | 0.3 | |
| | 1.0 | Axial(φ4.0/φ0.78) | RU 2 | 20 | -40 to +150 | 1.5 | 1.0 | 10 | 300 | 100(Ta) | 0.4 | 10/10 | 0.18 | 10/20 | 15 | 0.4 | |
| | 1.1 | Axial(φ4.0/φ0.78) | RU 2AM | 20 | -40 to +150 | 1.2 | 1.1 | 10 | 300 | 100 | 0.4 | 10/10 | 0.18 | 10/20 | 15 | 0.4 | |
| | 1.5 | Axial(φ4.0/φ0.98) | RU 3A | 20 | -40 to +150 | 1.5 | 1.5 | 10 | 400 | 100 | 0.4 | 10/10 | 0.18 | 10/20 | 12 | 0.6 | |
| | 1.5 | Axial(φ4.0/φ0.78) | RU 20A | 50 | -40 to +150 | 1.1 | 1.5 | 10 | 350 | 100 | 0.4 | 10/10 | 0.18 | 10/20 | 15 | 0.4 | |
| | 1.5 | Axial(φ4.0/φ0.98) | RU 3AM | 50 | -40 to +150 | 1.1 | 1.5 | 10 | 350 | 100 | 0.4 | 10/10 | 0.18 | 10/20 | 12 | 0.6 | |
| | 1.5(3.0) | Axial(φ6.5/φ1.4) | RU 4A | 50 | -40 to +150 | 1.5 | 3.0 | 10 | 300 | 100(Ta) | 0.4 | 10/10 | 0.18 | 10/20 | 8 | 1.2 | |
| | 3.0 | Axial(φ4.0/φ0.98) | RY2A | 50 | -40 to +150 | 1.15 | 3.0 | 10 | 1000 | 150 | 0.2 | 100/100 | 0.1 | 100/200 | 12 | 0.6 | |
| | 3.0 | TO-220F2Pin | FMU-1036S | 50 | -40 to +150 | 1.15 | 3 | 10 | 1000 | 150 | 0.2 | 100/100 | 0.1 | 100/200 | 4.0 | 2.1 | |
| | 5.0 | TO-220F2Pin | FMU-G16S | 30 | -40 to +150 | 1.25 | 5.0 | 50 | 500 | 100(Ta) | 0.4 | 100/100 | 0.18 | 100/200 | 4.0 | 2.1 | |
| | 5.0 | TO-220F(Center-tap) | FMU-16S, R | 30 | -40 to +150 | 1.5 | 2.5 | 50 | 500 | 100(Ta) | 0.4 | 100/100 | 0.18 | 100/200 | 4.0 | 2.1 | |
| 10 | TO-220F(Center-tap) | FMU-26S, R | 40 | -40 to +150 | 1.5 | 5.0 | 50 | 3000 | 150 | 0.4 | 100/100 | 0.18 | 100/200 | 4.0 | 2.1 | | |
| 10 | TO-220F2Pin | FMU-G26S | 40 | -40 to +150 | 1.35 | 10 | 50 | 500 | 150 | 0.4 | 100/100 | 0.18 | 100/200 | 4.0 | 2.1 | | |
| 10 | TO-220F2Pin | FMU-1106S | 180 | -40 to +150 | 1.15 | 10 | 30 | 3000 | 150 | 0.2 | 100/100 | 0.1 | 100/200 | 4.0 | 2.1 | | |
| 20 | TO-220F(Center-tap) | FMU-2206S* | 180 | -40 to +150 | 1.15 | 10 | 30 | 3000 | 150 | 0.2 | 100/100 | 0.1 | 100/200 | 4.0 | 2.1 | | |

*Under development

Package Type (Dimensions)

• No. 1 Surface-Mount (SJP)



• No. 2 Surface-Mount (D pack)

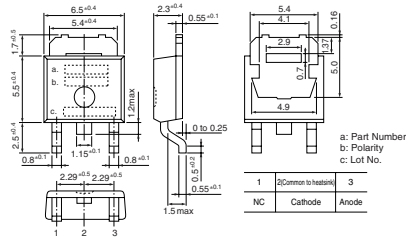

• No. 3 Surface-Mount (D pack) Center-tap

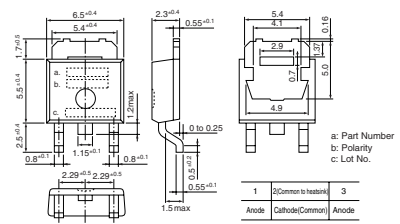

• No. 4 Surface-Mount (TO263)



• No. 5 Surface-Mount (TO220S)
MPL-102S, MP2-202S, MPL-1036

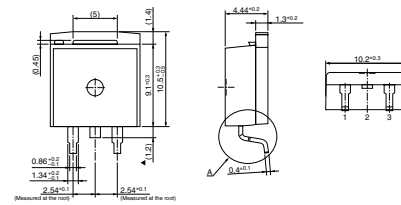

• No. 6 Surface-Mount (TO220S)

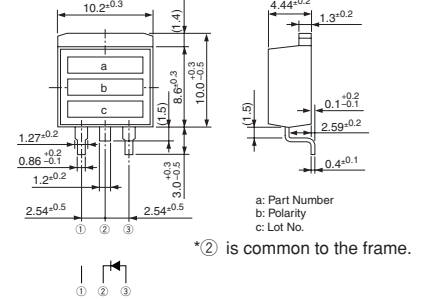

• No. 7 Surface-Mount (TO220S) Center-tap

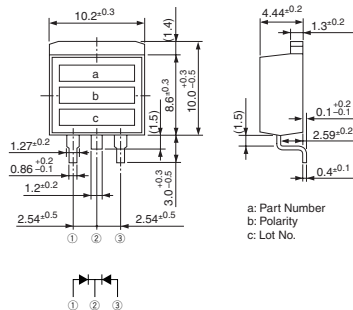

• No. 8 Surface-Mount (SZ-10)

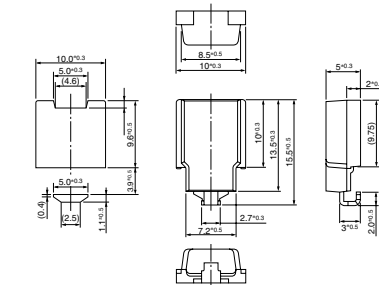

• No. 9 Axial (φ2.4/φ0.6)

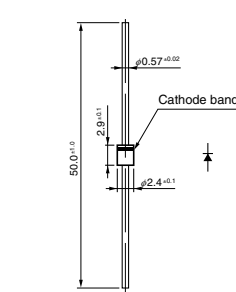

• No. 10 Axial (φ2.7/φ0.6)

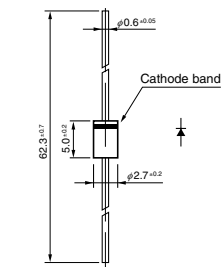

• No. 11 Axial (φ2.7/φ0.6)
Silicon Varistors (Symmetrical)

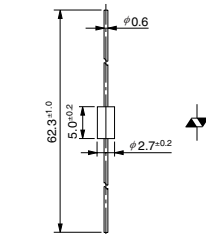

• No. 12 Axial (φ2.7/φ0.78)

