

4-3 Ultrafast Recovery Diodes

V _{RM} (V)	I _F (AV) (A) <small>Values in parentheses are for the products with heatsinks</small>	Package Axial <small>(Body Diameter/Lead Diameter)</small>	Part Number	I _{FSM} (A)	T _j (°C)	T _{stg} (°C)	V _F (V) max	I _F (A)	I _R (μA)	I _{R(H)} (mA)	T _a (°C)	trr ^① (ns)	I _F /I _{RP} (mA)	trr ^② (ns)	I _F /I _{RP} (mA)	R _{th(j-l)} (°C/W)	Mass (g)
				50Hz <small>Single Half Sine Wave</small>					V _R =V _{RM} max	V _R =V _{RM} max							
400	0.7	Axial (φ 2.4/φ 0.6)	AG01	15	-40 to +150	1.8	0.7	100	0.5	100	100	100/100	50	100/200	22	0.13	
	0.7	Axial (φ 2.7/φ 0.6)	EG01	15	-40 to +150	2.0	0.7	50	0.3	100	100	100/100	50	100/200	20	0.2	
	0.8	Axial (φ 2.7/φ 0.78)	EG 1	15	-40 to +150	1.8	0.8	50	0.3	100	100	100/100	50	100/200	17	0.3	
	1.0	Axial (φ 2.4/φ 0.6)	AL01	20	-40 to +150	1.4	1.0	10	0.5	150(T _j)	50	100/100	35	100/200	22	0.13	
	1.2	Axial (φ 4.0/φ 0.78)	RG 10	50	-40 to +150	1.8	1.5	500	2.5	100	100	100/100	50	100/200	15	0.4	
	1.2	Axial (φ 4.0/φ 0.98)	RG 2	50	-40 to +150	1.8	1.5	500	2.5	100	100	100/100	50	100/200	12	0.6	
	1.5	Axial (φ 2.7/φ 0.78)	EL 1	20	-40 to +150	1.3	1.5	10	0.05	100	100	100/100	50	100/200	17	0.3	
	2.0	Axial (φ 4.0/φ 0.98)	RL 2	40	-40 to +150	1.3	2.0	10	0.1	150(T _j)	50	100/100	35	100/200	12	0.6	
	1.0 (3.0)	Axial (φ 6.5/φ 1.4)	RG4S	80	-40 to +150	1.8	3.0	500	2.5	100	100	100/100	50	100/200	8	1.2	
	3.5	Axial (φ 5.2/φ 1.2)	RL 3	80	-40 to +150	1.3	3.5	100	0.2	150(T _j)	50	100/100	35	100/200	10	1.0	
	5.0	TO-220F2Pin	FMXA-1054S	50	-40 to +150	1.5	5.0	50	15	150	20	500/500	—	—	4.0	2.1	
	5.0	TO-220F (Center-tap)	FMG-14S, R	35	-40 to +150	2.0	2.5	500	1.5	100	100	100/100	50	100/200	4.0	2.1	
	5.0	TO-220F (Center-tap)	FML-14S	40	-40 to +150	1.3	2.5	50	0.1	100	50	100/100	35	100/200	4.0	2.1	
	5.0	TO-220F2Pin	FMX-G14S	70	-40 to +150	1.3	5.0	50	15	150	30	100/100	25	100/200	4.0	2.1	
	5.0	TO-220F2Pin	FML-G14S	70	-40 to +150	1.3	5.0	100	0.2	100	50	100/100	35	100/200	4.0	2.1	
	5.0	TO-220F2Pin	FMN-G14S	70	-40 to +150	1.0	5.0	50	10	150(T _j)	100	100/100	50	100/200	4.0	2.1	
	8.0	TO-220F (Center-tap)	FMG-24S, R	65	-40 to +150	2.0	5.0	500	2.5	100	100	100/100	50	100/200	4.0	2.1	
	10.0	TO-220F (Center-tap)	FML-24S	70	-40 to +150	1.3	5.0	100	0.2	100	50	100/100	35	100/200	4.0	2.1	
	10.0	TO-220F2Pin	FMXA-1104S	100	-40 to +150	1.5	10.0	100	30	150(T _j)	25	500/500	—	—	4.0	2.1	
	16.0	TO-220F (Center-tap)	FMXJ-2164S	100	-40 to +150	1.4	8.0	100	20	150(T _j)	18	500/500	—	—	4.0	2.1	
20.0	TO-3PF (Center-tap)	FML-4204S	100	-40 to +150	1.3	10.0	50	0.4	150	50	500/500	35	500/1000	2.0	6.5		
20.0	TO-3PF (Center-tap)	FMXA-4204S*	100	-40 to +150	1.5	10	100	30	150(T _j)	25	500/500	—	—	2.0	6.5		
20.0	TO-3PF (Center-tap)	FMD-4204S	100	-40 to +150	1.4	10	20	0.2	150(T _j)	50	500/500	25	500/1000	2.0	6.5		
500	1.0	Axial (φ 4.0/φ 0.78)	RD1105*	20	-40 to +150	1.4	1.0	10	0.1	150(T _j)	40	100/100	30	100/200	12.0	0.4	
	3.0	Axial (φ 5.2/φ 1.2)	RD3305	50	-40 to +150	1.4	3.0	15	0.15	150(T _j)	50	100/100	35	100/200	10.0	1.0	
600	0.5	Axial (φ 2.7/φ 0.6)	EG01A	10	-40 to +150	2.0	0.5	100	0.5	100	100	100/100	50	100/200	20	0.2	
	0.5	Axial (φ 2.4/φ 0.6)	AG01A	15	-40 to +150	1.8	0.5	100	0.5	100	100	100/100	50	100/200	22	0.13	
	0.6	Axial (φ 2.7/φ 0.78)	EG 1A	10	-40 to +150	2.0	0.6	100	0.5	100	100	100/100	50	100/200	17	0.3	
	1.0	Axial (φ 4.0/φ 0.78)	RG 10A	50	-40 to +150	2.0	1.0	500	2.5	100	100	100/100	50	100/200	15	0.4	
	1.0	Axial (φ 4.0/φ 0.98)	RG 2A	50	-40 to +150	2.0	1.0	500	2.5	100	100	100/100	50	100/200	12	0.6	
	1.2	Axial (φ 4.0/φ 0.98)	RD 2A	30	-40 to +150	1.55	1.2	50	0.1	150(T _j)	50	100/100	35	100/200	12	0.6	
	2.0	Axial (φ 5.2/φ 1.2)	RL 3A	60	-40 to +150	1.7	3.0	50	0.2	150(T _j)	50	100/100	35	100/200	10	1.0	
	1.0 (2.0)	Axial (φ 6.5/φ 1.4)	RG 4AS	50	-40 to +150	2.0	2.0	500	2.5	100	100	100/100	50	100/200	8	1.2	
	3.0	TO-220F (Two elements)	FMC-26U	50	-40 to +150	2.0	3.0	500	3	150(T _j)	70	500/500	35	500/1000	4.0	2.1	
	3.0	Axial (φ 6.5/φ 1.4)	RL 4A	80	-40 to +150	1.5	3.0	50	0.1	150(T _j)	50	500/500	35	500/1000	8	1.2	
	3.0	Axial (φ 6.5/φ 1.4)	RN4A	50	-40 to +150	1.3	3.0	50	5	150(T _j)	100	100/100	50	100/200	8.0	1.2	
	4.0	TO-220F2Pin	FMG-G26S	50	-40 to +150	2.5	4.0	500	3	100	100	100/100	50	100/200	4.0	2.1	
	5.0	TO-220F2Pin	FMX-G16S	50	-40 to +150	1.5	5.0	50	15	150	30	100/100	25	100/200	4.0	2.1	
	5.0	TO-220F2Pin	FML-G16S	50	-40 to +150	1.5	5.0	100	0.5	100	50	500/500	35	500/1000	4.0	2.1	
	5.0	TO-220F2Pin	FMN-G16S	50	-40 to +150	1.2	5.0	50	10	150(T _j)	100	100/100	50	100/200	4.0	2.1	
	5.0	TO-220F2Pin	FMN-1056S	60	-40 to +150	1.3	5.0	50	5.0	150	100	100/100	50	100/200	4.0	2.1	
	5.0	TO-220F2Pin	FMD-1056S	90	-40 to +150	1.7	5.0	10	0.1	150	50	500/500	35	500/1000	4.0	2.1	
	6.0	TO-220F (Center-tap)	FMG-26S, R	50	-40 to +150	2.2	3.0	500	3	100	100	100/100	50	100/200	4.0	2.1	
	8.0	TO-220F2Pin	FMXK-1086S	100	-40 to +150	1.75	8	30	6.0	150	27	500/500	—	—	4.0	2.1	
	10.0	TO-220F2Pin	FMX-G26S	100	-40 to +150	1.5	10.0	100	20	150	30	100/100	25	100/200	4.0	2.1	
10.0	TO-220F2Pin	FMD-G26S	100	-40 to +150	1.7	10.0	100	0.3	100	50	500/500	30	500/1000	4.0	2.1		
10.0	TO-220F2Pin	FMXA-1106S	100	-40 to +150	1.98	10.0	100	30	150(T _j)	28	500/500	—	—	4.0	2.1		
10.0	TO-220F2Pin	FMNS-1106S	100	-40 to +150	1.3	10	100	10	150	100	100/100	50	100/200	4.0	2.1		
10.0	TO-220F2Pin	FMN-1106S	150	-40 to +150	1.3	10	100	10	150	100	100/100	50	100/200	4.0	2.1		
10.0	TO-220F2Pin	FMD-1106S	180	-40 to +150	1.7	10	20	0.2	150	50	500/500	35	500/1000	4.0	2.1		
10.0	TO-220F2Pin	FMXK-1106S	100	-40 to +150	1.75	10	100	10	150	27	500/500	—	—	4.0	2.1		
20.0	TO-220F (Center-tap)	FMN-2206S	150	-40 to +150	1.3	10	100	10	150	100	100/100	50	100/200	4.0	2.1		
20.0	TO-220F (Center-tap)	FMXK-2206S	100	-40 to +150	1.75	10	100	10	150	27	500/500	—	—	4.0	2.1		
20.0	TO-3PF (Center-tap)	FMD-4206S	100	-40 to +150	1.7	10.0	100	0.3	150	50	500/500	30	500/1000	2.0	6.5		
20.0	TO-3PF (Center-tap)	FMX-4206S*	100	-40 to +150	1.5	10	100	20	150(T _j)	30	500/500	25	500/1000	2.0	6.5		
20.0	TO-3PF (Center-tap)	FMXA-4206S*	100	-40 to +150	1.98	10	100	30	150(T _j)	28	500/500	—	—	2.0	6.5		
20.0	TO-3PF (Center-tap)	FMN-4206S	150	-40 to +150	1.3	10	100	10	150(T _j)	100	100/100	50	100/200	2.0	6.5		

Package Type (Dimensions)

• No. 1 Surface-Mount (SJP)



• No. 2 Surface-Mount (D pack)



• No. 3 Surface-Mount (D pack) Center-tap

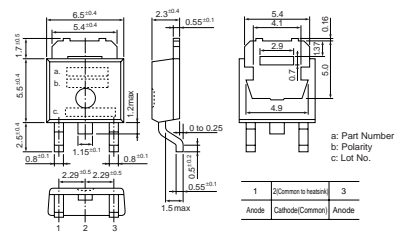

• No. 4 Surface-Mount (TO263)

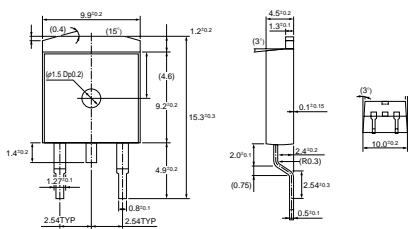

• No. 5 Surface-Mount (TO220S)
MPL-102S, MP2-202S, MPL-1036

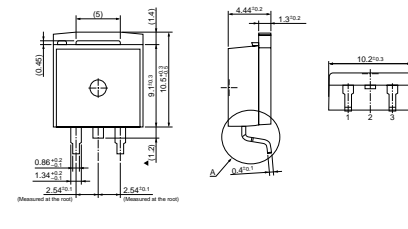

• No. 6 Surface-Mount (TO220S)

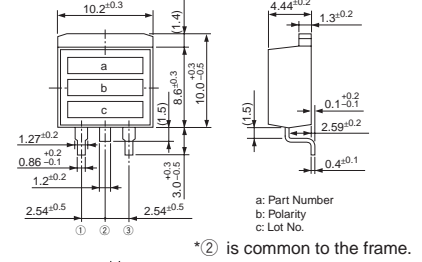

• No. 7 Surface-Mount (TO220S) Center-tap

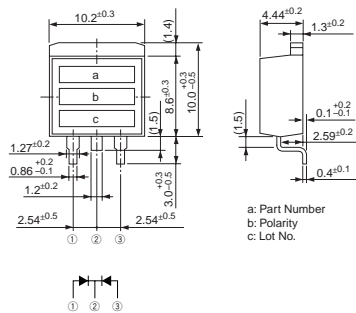

• No. 8 Surface-Mount (SZ-10)

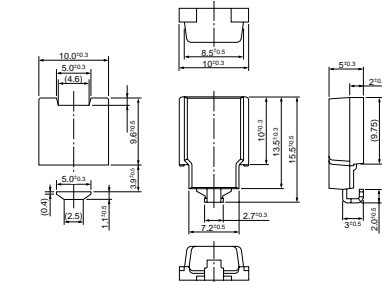

• No. 9 Axial (φ2.4/φ0.6)

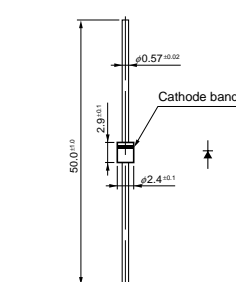

• No. 10 Axial (φ2.7/φ0.6)

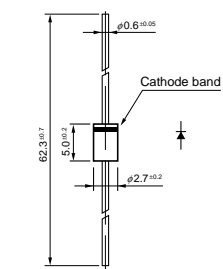

• No. 11 Axial (φ2.7/φ0.6)
Silicon Varistors (Symmetrical)

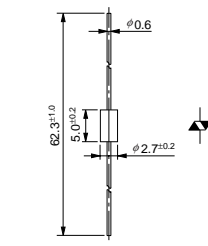

• No. 12 Axial (φ2.7/φ0.78)

